



DRIVEN BY POSSIBILITY™



盖茨液压产品手册

胶管、胶管接头

2023





管路系统**全面解决方案**

源于您值得信赖的百年品牌

- 液压胶管
- 工业特种胶管
- 软硬管一体式总成
- 过渡接头
- 快换接头、球阀
- 管路设备
- 管路附件
- 工程服务
- 应用、技术支持
- 产品设计、研发
- 培训
- 全球资源

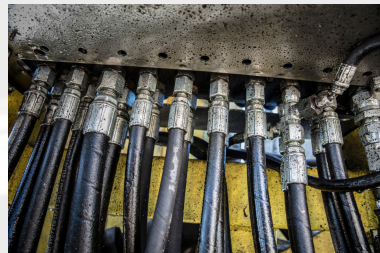

产品目录

项目指南

液压胶管

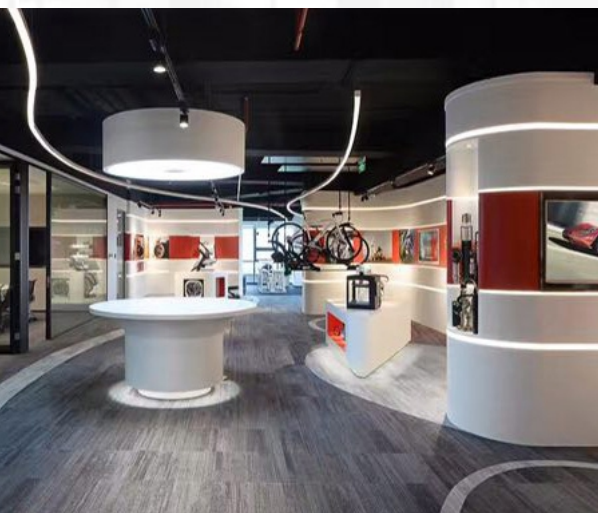

■ 编织管系列	
MXT™ 软管	1
M6K Mega6000® 2层钢丝编织管	1
M5K Mega5000® 2层钢丝编织管	2
M4K Mega4000® 2层钢丝编织管/ SAE 100 R19	2
M3K Mega3000® 1-2层钢丝编织管/ SAE 100 R17	3
G1 1层钢丝编织管/ SAE 100 R1	3
G2 2层钢丝编织管/ SAE 100 R2	4
CR1 1层钢丝编织软管/ SAE 100 R1	4
CR2 2层钢丝编织软管/ SAE 100 R2	5
M2T MegaFlex® 2层钢丝编织管/ SAE 100 R16	5
■ 缠绕管系列	
MXG™4K 软管	6
MXG™5K 软管	6
G8K / 8000 psi 6层钢丝缠绕管	7
EFG6K / 6000 psi 4-6层钢丝缠绕管/ SAE 100 R15	7
EFG5K / 5000 psi 4-6层钢丝缠绕管/ SAE 100 R13	8
EFG4K / 4000 psi 4-6层钢丝缠绕管/ SAE 100 R12	8
EFG3K / 3000 psi 4层钢丝缠绕管/ SAE 100 R12	9
4XP 4层钢丝缠绕管/ EN856 4SP	9
4XH 4层钢丝缠绕管/ EN856 4SH	10
■ 专用管系列	
MULTI MASTER® GMV™ MEGAFLEX® 吸油、回油、排放专用管/ SAE 100 R4	11
J2AT 千斤顶专用管 / IJ100	11
■ 多用途纤维编织管	
LOL/Plus Lock-On 即插免卡箍软管	12
GTH 高温1层纤维管/ SAE 100 R6	12
RLA 1层纤维管/ SAE 30 R2	13
G3H 高温2层纤维管/ SAE 100 R3	13
■ 热塑管系列	
TH7 / TH7NC / SAE 100 R7	14
TH7DL 双联管/ SAE 100 R7	14
TH8 / TH8NC / SAE 100 R8	15
TH18 / TH18NC / SAE 100 R18	15
■ 高温环境系列	
C14 不导电氟龙管/ SAE 100 R14	16
M3KH 小弯曲半径、恒压1-2层钢丝编织管	16
MAGETECH G5TB OIL-AIR RETURN 2层编织高温管	17
MAGETECH 1000 OILRETURN 高温回油管、制动管	17
G1H 1层钢丝编织高温管/ SAE 100 R1	18
G2XH 2层钢丝编织高温管/ SAE 100 R2	18
M4KH 2层钢丝编织高温管/ SAE 100 R19	19
■ 低温环境系列	
M4KL 小弯曲半径、恒压1-2层钢丝编织管	20
G2L PolarFLEX 2层钢丝编织管	20
EFG6KL 4层钢丝编织管	21
EFG5KL 4-6层钢丝编织管	21
EFG4KL 4层钢丝编织管	21

胶管接头

GlobalSpiral™ 缠绕管分体式接头	23
GlobalSpiral™ 缠绕管分体式扣套	45
GlobalSpiral™ 缠绕管一体式接头	47
MegaCrimp™ 编织管一体式接头	57

MegaSys® 恒压、小弯曲半径胶管特性

恒压力软管

MegaSys® 产品线由恒定压力的缠绕及编织软管组成，弯曲半径最多可以达到 SAE 标准规定的 1/3。配以专门开发的创新接头，即使在高达 8,000 psi 的工作压力之下仍然可以保证无泄漏。

MegaSys® 的优点

- 恒定标称压力简化软管选型
- 最大可以达到 SAE 规定的弯曲半径的 1/3
- 节约总成的整体长度
- 紧凑工作空间内方便布管
- 降低对弯头使用数量
- 更好的柔性方便安装
- 降低库存要求
- 在弯曲的场合使用寿命更长
- 可以提供耐磨表面 XtraTuff™ 或者 MegaTuff®
- 降低成本，最多可达 64%
- 压力可视化管理系统

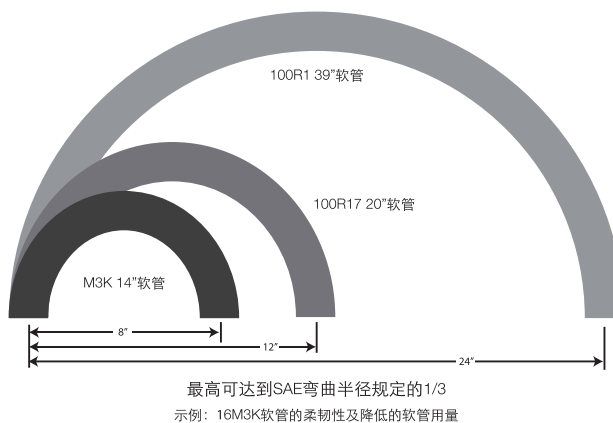

可视化 MegaSys® 软管压力色码表

3000 psi	4000 psi	5000 psi	6000 psi	8000 psi
M3K/EFG3K	M4K/EFG4K	M5K/EFG5K	M6K/EFG6K	G8K

1-2 层钢丝编织管，60 万次高脉冲设计标准



4-6 层钢丝编织管，100 万次高脉冲设计标准



MegaSys® 恒压、小弯曲半径胶管特性

可选择性耐磨外胶

试验证明，盖茨的可用于 MegaSys® 的耐磨外胶层可以承受最为恶劣的操作工况。这些外胶层可以增加软管服务寿命，降低维护及更换成本，无需弹簧护套，尼龙护套等附加防护套。

MegaTuff® 软管外胶

- 极其坚固的外胶解决了磨损问题
- 比标准软管外胶高出 300 倍的耐磨性
- 经过 1 百万次脉冲试验
- 耐油，臭氧及紫外线
- 表现优于目前市场上所有其他产品

XtraTuff™ 软管外胶

- 出色的耐磨外胶
- 比标准软管外胶高出 25 倍的耐磨性
- 耐油，臭氧及紫外线

耐磨测试

ISO6945—使软管损失 1 克重量所需要的金属-软管摩擦循环次数

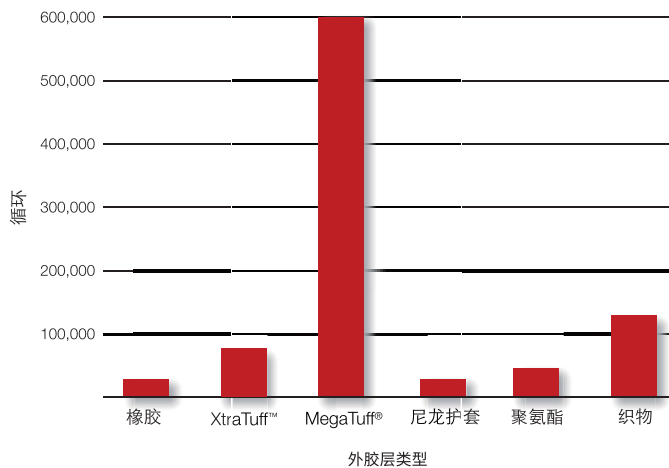

更严格的测试，为超群的质量，可靠性及价值提供保证

盖茨品质的核心是严格的测试及产品论证。从产品开发到制造，盖茨致力于向全球市场提供寿命更长，表现更佳，价值更高的产品。

MegaSys® 产品线都经过工业标准，以及竞争产品的比对测试。无论参照的是一个现成的新产品还是在开发中的新概念，盖茨的目标是持续达到或者超越行业标准，领先竞争对手。

- MegaSys® 软管通过了苛刻的柔韧性脉冲试验，在最高达 1 百万次的脉冲下弯曲软管，用以模拟苛刻的设备使用条件。
- 在模拟恶劣的操作环境下对软管外胶进行测试以证明其耐受不恰当使用，磨损，油污，化学物质以及气候条件的能力远远强于普通软管。
- 接头的开发和设计都经过试验，以保证在当今工作压力越来越高的设备上使用时不会泄漏。
- 无论是软管还是接头的镀层，所有的选材必须通过实验室论证，并且通过实地考验，保证可以承受最恶劣的环境条件。
- 标准化软管，接头及总成扣压流程也为稳定可靠的产品表现提供了保证。



盖茨软管接头特性

MEGACRIMP 软管接头 - 使您放心的扣压端密封效果

MegaCrimp 软管接头带给您创新的防泄漏密封效果，并且已经获得专利保护！事实上，在设计测试的阶段，它成功承受了超过 1 百万次脉冲循环。



革命性的 MegaCrimp 软管接头

秘密就在内部

MegaCrimp 软管接头取得如此表现的秘密在于其内部设计。即使是不同构造和壁厚的软管，也可以使用同样的“C”型插环。

另外，“C”型插环可以保证扣压力在周向的平均分布，形成一个同心的密封。您的库存将得到简化，因为一个尺寸的“C”型插环就可以满足不同的软管外径，一层或者两层钢丝的软管。还有更多：MegaCrimp 软管接头还完全满足 EN 标准的性能规定。



专利的“C”型插环

主要特点

MegaCrimp 软管接头建立了液压软管接头的新基准。独特的“C”型插环保障了不泄漏的同心扣压，保持设备及环境的清洁。

全扭矩螺母设计

液压泄漏最常见的原因之一是臂力强劲的工作人员把接头的螺母或者密封座拧坏了。盖茨开发出了解决方案 - 全扭矩螺母现在已经在盖茨的 MegaCrimp 和 GlobalSpiral™ 软管接头上得到了使用。



主要特征

- 内螺纹JIC及平面O型圈
全部采用全扭矩螺母设计
- 牢固的“咬上钢丝”的扣压
- 通用性
- 紧凑设计
- 接头芯全尺寸插入
- 全尺寸的扣压
- 库存便于管理，降低库存单元
- TuffCoat®镀层提供5倍抗
腐蚀性能
- 完全满足EN标准性能要求

盖茨软管接头特性



“C”型插环始终保持圆度

在扣压过程中，MegaCrimp® 软管接头只有外套部分承受扣压模具的形状。而在内部，“C”型插环的圆度得到保持 - 和软管保持一致，而没有产生多边形效应。图示是其他厂商的一件式扣压接头的剖面，它显示了扣压可能破坏软管的内层，而这种破坏常常导致泄漏通道的形成。而 MegaCrimp 软管接头则保持圆形。

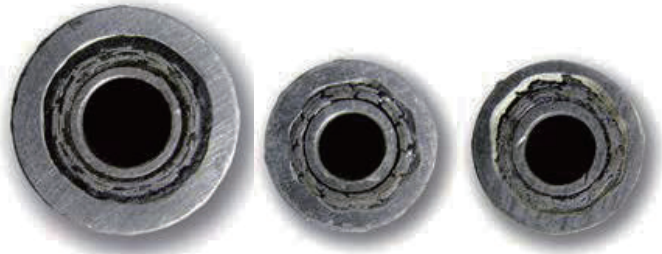

盖茨的 MegaCrimp
软管接头

其他品牌

其他品牌

MEGACRIMP 独特的 TUFFCOAT® 镀层

这一创新的镀层使我们的 MegaCrimp 软管接头的耐腐蚀性比从前提高 4 倍。这意味着即使在苛刻的 SAE-J516 及 ASTM-117 盐雾喷射环境下，也可以达到 400 小时的红锈保护。



盖茨的 TuffCoat

在盐雾试验过程中随机抽取的阶段拍摄的照片显示，盖茨的 TuffCoat 镀层对红锈的保护显著强于对比产品。

(接头上的白色斑点是盐的残渣，不是腐蚀。)



MegaCrimp 的插入力也得到优化。不过分的紧，也不过分的松弛。事实上，在它插到底部时，你甚至可以感觉到。

在扣压过程中，MegaCrimp 软管接头也保持插入，而不会脱落。



上图所示为 MegaCrimp 的领先齿形设计如何“咬上钢丝”而达到最大的咬合力。而下图所示为依靠挤压橡胶外层及内管的其他扣压。

MegaSys® 产品特点及软管的命名

MegaSys® 恒压编织管

M3K, M4K, M5K, M6K 软管

- 每种软管都是恒定压力
- 两层高强度钢丝编织 (-3、-4、-5、-6 和 -8 的 M3K 软管是 1 层)
- 丁腈内胶适用于可生物降解的液压流体
- 测试通过行业领先的 60 万次脉冲
- 温度范围是 -40° F 到 +212° F (-40° C 到 +100° C)
- 拥有耐磨 XtraTuff 和超耐磨 MegaTuff 表面
- “H” 表示 -40° F 到 +250° F
- “L” 表示 -70° F 到 +212° F

MegaSys® 恒压缠绕管

EFG3K, EFG4K, EFG5K, EFG6K 和 G8K 软管

- 每种软管都是恒定压力
- 四层高强度钢丝缠绕 (部分大口径的为 6 层)
- 丁腈内胶适用于可生物降解的液压流体 (G8K 内胶为氯丁橡胶)
- 测试通过行业领先的 100 万次脉冲
- 温度范围是 -40° F 到 +212° F (-40° C 到 +100° C)
- 拥有超耐磨 MegaTuff 表面
- “L” 表示 -70° F 到 +212° F

3000 psi	M3K/EFG3K
4000 psi	M4K/EFG4K
5000 psi	M5K/EFG5K
6000 psi	M6K/EFG6K
8000 psi	G8K

MegaSys® 软管标记线系统

所示为专为 MegaSys® 软管开发的标记线。独特的设计以及压力色码使 MegaSys® 在库存或者使用状况下更加容易识别。

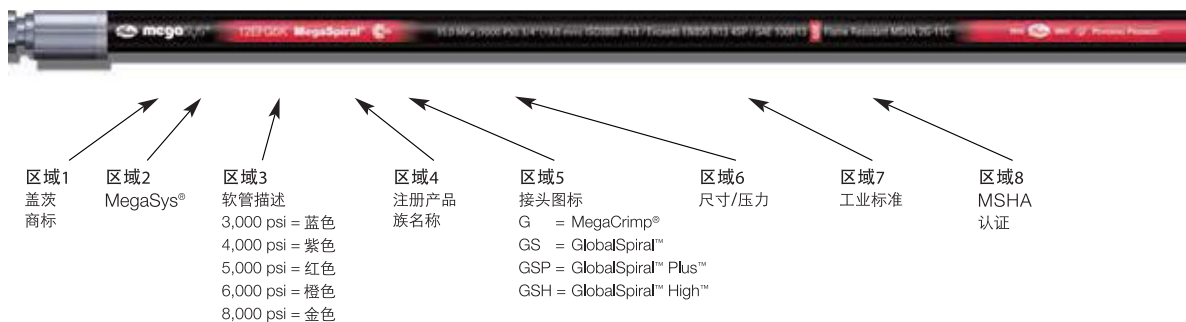

行业机构范围和认证

行业机构规范和软管选择指南

行业机构

ABS	美国船级社
AS	澳大利亚标准
DIN	德国工业标准
DNV	北海轮船挪威船级社
EN	欧洲标准
GL	德国劳氏船级社
IJS	工业千斤顶标准
RCCC	重型卡车和公共汽车运输协会
SAE	汽车工程师协会

政府机构

DOT/FMVSS	美国交通部 / 联邦汽车安全标准
MSHA	美国矿山安全和健康署
USCG	美国海岸警卫队
MA	中国煤安认证

我们可以满足以上机构的规范要求

软管类型	ABS	AS	DIN	DNV	EN	GL	IJS	RCCC	SAE	DOT/FMVSS	MSHA	USCG J1942		MA
												燃料油	动力装置	
EFG6K	✓	✓	20023 4SH/4SP	✓	EN 856 4SH/4SP				100R15		✓	✓	✓	
EFG5K	✓	✓	20023-4SH/4SP	✓	EN 856 4SH/4SP				100R13		✓	✓	✓	
EFG4K	✓	✓	20023 4SP		EN 856 4SP				100R12		✓	✓	✓	
EFG3K	✓		20023 4SP		EN 856 4SP				100R12		✓	✓	✓	
M5K		✓		✓		✓								
M4K	✓	✓		✓		✓			100R19		✓		✓	
M4KH	✓					✓			100R19		✓		✓	
G2XH									100R2 Type AT		✓		✓	
G2AT-HMP									100R2 Type AT		✓		✓*	
M2T®	✓	✓		✓	EN 853 2SN				100R16		✓		✓	
CM2T				✓	EN 857 2CS				100R16		✓		✓	
G2	✓	✓	20022 2SN	✓	EN 853 2SN	✓			100R2 Type AT		✓		✓	✓
G2H		✓		✓	EN 853 2SN				100R2 Type AT		✓	✓		
J2AT							✓				✓		✓	
M3K	✓	✓		✓	EN 857	✓			100R17		✓		✓	
M3K-12, -16	✓	✓		✓	EN857	✓			100R17, 100R9		✓	✓	✓	
G1	✓	✓	20022 1SN	✓	EN 853 1SN	✓			100R1 Type AT		✓			✓
G1H				✓	EN 853 1SN				100R1 Type AT		✓	✓		
MegaTech™									J1402, J1405	106-74(-4to-10)				
TR500									J1402	106-74				
NABT									J844					
C5C								RP305(B)	100R5	106-74TypeAll(-4to-10)				
C5E									J1405	106-74 TypeAll				
C5D									J1405	106-74 TypeAll				
C5M	✓								J30R2, J1527		✓	✓		
G3H					EN 854 R3				100R3					
GTH, GTHX					EN 854 R6				100R6				✓	
GMV	✓@	✓							100R4		✓			
LOL											✓			
热塑性塑料														
TH7, TH7NC***									100R7					
TH8, TH8NC									100R8					
TH18, TH18NC									100R18					
C14									100R14					
制冷剂														
PolarSeal® AC134a									J51Type 2, J2064					
动力转向														
PS188									2050					

* 不包括 1/4"

***TH7NC 符合 ANSI A92.2 "车载天线装置" (-3 到 -8)

@ 与防火护套配合使用

** 不包括 3/8" & 1/2"

软管 - 接头适配表

接头适配表

	分体式设计		一体式设计
	接头芯	外套	
EFG6K	GS(用于划线规格 -6 至 -16) GS(用于划线规格 -20)	GS1F-4(dash size 划线规格 6-16) GS1F-6(用于划线规格 -20)	
EFG5K	GS(用于划线规格 -6 至 -16) GS(用于划线规格 -20)	GS1F-4(dash size 划线规格 -6 至 -16) GS1F-6(用于划线规格 -20)	一体式接头 GSH, GSM (用于划线规格 -24, -32)
EFG4K	GS	GS1F-4	
EFG3K	GS(用于划线规格 -20) GSP(用于划线规格 -24, -32)	GS1F-4(用于划线规格 -20) GSP1F-4(用于划线规格 -24, -32)	
M3K	Power Crimp(用于划线规格 -3)	PS1FS(用于划线规格 -3)	G(用于划线规格 -4 至 -16)
M4K			G
M5K			G
M6K			G
M-XP			G
GMV			GL(用于划线规格 -24, 至 -64) G(用于划线规格 -12to-20)
M2T			G
G2XH			G
G2L PolarFlex	GSP(用于划线规格 -24, -32)	GSP1F-2(用于划线规格 -24, -32)	G
J2AT			G-Male Pipe Long Nose
Mega Tech II	GSP(用于划线规格 -24, -32)	GSP1F-2(用于划线规格 -24, -32)	G(用于划线规格 -20)
MegaTech 3000			G
MeagTech® 1000			G(用于划线规格 -4 至 -10) GL(用于划线规格 -12 至 -20)
MegaTech® 500	GSP(用于划线规格 -24, -32)	GSP1F-2(用于划线规格 -24, -32)	GL(用于划线规格 -40, -48)
MegaTech® 250			GLP(用于划线规格 -4 至 -12) G(用于划线规格 -16 至 -20)
MegaTech® G5TB			G GL(用于划线规格 -24 至 -32)
M500			G
RLA 1	Power Crimp(用于划线规格 -3)	PC1FS(用于划线规格 -3)	G
RLC 3			卡箍
MegaTech® LOC 1			GLP(用于划线规格 -4 至 -12) G
LOC 1			GLP
LOL Plus Lock	Power Crimp(用于划线规格 -3)	PC1FS(用于划线规格 -3)	GLP
G2	Power Crimp(用于划线规格 -3) GSP(用于划线规格 -24, -32)	PC12F(用于划线规格 -3) GSP1F(用于划线规格 -24, -32)	G
G2H	GSP(用于划线规格 -24, -32)	GSP1F-2(用于划线规格 -24, -32)	G
G1	Power Crimp(用于划线规格 -3) GSP(用于划线规格 -24, -32)	PC1FS(用于划线规格 -3) GSP1F-2(用于划线规格 -24, -32)	G
G1H	GSP(用于划线规格 -24, -32)	GSP1F-2(用于划线规格 -24, -32)	G
G3H	Power Crimp	PC2F	
GTH	Power Crimp(用于划线规格 -3)	PC1FS(用于划线规格 -3)	G
GTHX			G(用于划线规格 -12 至 -20)
G4H			G
C5C			C5 可拆式接头
C5D			C5 可拆式接头
C5M			C5 可拆式接头
C5E			C5 可拆式接头
RFS	Power Crimp(用于划线规格 -3)	PC1FS(用于划线规格 -3)	G(用于划线规格 -4 至 -16)
4XP	GS	GS1F-4	
4XH	GS	GS1F-4	

重要信息

使用盖茨液压软管总成，获取最佳使用寿命

液压软管总成的使用寿命取决于它的使用条件。本产品目录和盖茨的其他资料中提供了对我们的总成产品在安装、维护和使用过程中推荐的使用限制（包括构成总成的软管和接头）。用户必须遵循这些限制，否则可能由于软管总成的失效而导致人身伤害或财产损失。

应定期检查使用中的软管总成是否出现泄漏、扭结、外胶层起泡、擦伤、磨损或其他损坏。发现总成损坏或磨损后，必须立即更换。可以通过以下措施来延长总成的使用寿命：

软管总成的安装： 液压软管总成的安装应符合 SAE J1273 关于液压软管走向及布置的相关标准，以保证软管总成得到正确的使用。

工作压力： 液压系统压力不应该超过软管的额定工作压力。超过额定工作压力的压力陡升或峰值是极具破坏性的，在选择软管时，必须加以考虑。

最低爆破压力： 本产品目录中所指的爆破压力仅限于破坏性试验以决定设计安全系数的目的。

温度范围¹： 不要在超过推荐极限的温度条件（包括内部及外部温度）下使用软管。如果使用的液压流体中含有乳剂或溶液，请另行查阅相关的技术数据。无论软管的使用温度范围多大，都不得超过流体生产商建议的最高使用温度。

流体兼容性： 液压软管总成（内胶层，外胶层，增强层及软管接头）必须与使用的流体相兼容。必须使用恰当的软管，因为磷酸酯基和石油基的液压流体的化学特性是截然不同的，很多软管适用于一种或多种流体，但是并不是适合所有的流体类型。比如：盖茨的 G2XH, MegaTech[®] 和 C5D 软管既能用于磷酸酯基又能用于石油基的液压流体。

最小弯曲半径： 不得将软管弯折小于推荐的最小弯曲半径，也不得使软管承受张力或者扭矩，这样可能使增强层承受过度的应力，极大的降低软管承受压力的能力。

软管尺寸： 软管尺寸（内径）必须能够处理要求的流量，在特定流量下，如果内径太小，会造成过度的流体压力并产生热量，造成内胶层损坏。

软管走向布置： 要对软管进行约束、保护或引导（必要时使用管夹），以尽量减少因为过度的挠曲、抖动或接触移动部件或腐蚀性而造成破坏的风险。确定合适的软管长度及接头形式以防止磨损，避免接触尖锐物以及产生扭曲，从而达到防止泄漏的连接。

软管长度： 确定正确的软管长度时应将在压力下、机器振动和运动时以及软管总成布线时的长度变化考虑在内。

软管应用： 根据具体的应用选择适当的软管。吸油应用（盖茨 GMV 或 G4H），特殊流体或高温性能是需要特殊考虑使用专门软管的应用实例。如果需要进一步了解这些方面的情况，请与您所在地区盖茨业务代表联系。

注意：不要用盖茨软管代替刚性管线

¹ 当温度接近建议的使用限时，其实际使用寿命将取决于具体的使用环境和软管中的液压油种类。间歇性温升（最长可达运行时间的 10%）系指瞬时的温度陡升。接触高温的时间越长，对使用寿命的不利影响也越强。

软管的存放寿命

保存环境，连同橡胶材料可以改变软管的存放寿命，具体的使用寿命是很难量化的，因为影响软管的因素有很多。如果存储措施得当，存放寿命可以达到 3-5 年。超过这一时间，软管的使用寿命会大大降低，具体的情况取决于存放环境中的各种因素，其中包括：

- 温度：软管应存放在阴凉干燥处，温度一定不要超过 +100° F (+38°C)。如果在冰点以下温度中存放，取出后可能需要先进行预热，然后才能进行处理、测试和投入使用。
- 阳光直射、雨水、加热器或靠近电气设备。
- 潮湿和臭氧。
- 油、溶剂、腐蚀性材料或烟气。
- 昆虫或啮齿动物。
- 放射性。
- 可用空间及是否存在弯曲。

软管应存放在原始容器中。不要堆得太高，否则其自身的重量会压坏最底层的软管。

盖茨建议在使用存放时间较长的软管前进行目测及测试。被判断为状况不好的软管，应予以更换，以免造成失效、财产损失或人身伤害。仓库要按先进先出的原则进行管理。存放时间过长、环境差都会造成软管等级下降，性能降低并可能导致过早失效。



警告

以下原因可以导致液压软管总成爆破或者拔脱，从而造成严重的人身伤害、死亡或财产损失：

- 总成损坏或磨损；
- 扣压或安装不正确。

盖茨公司的有限质量保证

盖茨公司保证其在发运给客户后二十四(24)个月内不会出现材料或制作工艺上的缺陷。如果有证据表明出售的商品有材料或制作工艺上确实存在缺陷(或二者都有)，盖茨公司可以选择进行更换或修理。任何质量保证期内的索赔应在质量保证期截止前六(6)个月内提出，否则盖茨将不予受理。这是盖茨公司违反质量保证规定而对客户的唯一补救，也是全部的补救，金额仅限于客户购买产品的价格。如果因为滥用、误用、不当使用、维护不充分或没有按盖茨公司发布的安装、使用和维护建议操作或维护而造成产品损坏，则本质量保证自动失效。如在质量保证期内需要保修服务，请与盖茨公司客户服务部联系(科罗拉多州丹佛市威瓦塔街1551号 1551 Wewatta Street, Denver, Colorado 80202)。在此，盖茨明确声明不对包括但不限于产品的适用性和对具体用途的适用性提供任何其他明示或暗示的质量保证。对于任何连带的、附带的、专门性的、惩罚性的和间接的赔偿，包括但不限于利润损失，不论该损害是可以合理预见的或者盖茨公司拥有其可能发生的知识，盖茨公司不承担任何责任。有些州不允许对附带的或连带的伤害进行免除或限制，而有些州不允许对默示的质量保证期限进行限制，因此上诉的限制和免除情况可能不适合您的情况。本质量保证提供了特定的法律权利，而根据不同的州的情况，您也可能还享有其他权利。

MXT™ 软管

标准	SAE100R16, SAE100R17, SAE100R2 和SAE100R19
结构	黑色耐油合成内胶, 高强度钢丝编织而成的增强层
外胶	XtraTuff™ 适用于有摩擦的工况, XTP外胶比标准胶管外胶耐磨25倍
温度范围	-40°C至+100°C
适配接头	一体式G系列



标准管	XTP耐磨管	inch		mm	inch		mm	psi		Mpa	psi		Mpa	inch		mm
4MXT	4MXT-XTP	1/4		6.3	0.55		14.0	6000		41.4	24000		165.5	1.5		38.1
5MXT	5MXT-XTP	5/16		7.9	0.61		15.5	5500		37.9	22000		151.7	1.8		45.7
6MXT	6MXT-XTP	3/8		9.5	0.68		17.3	4800		33.1	19200		132.4	2.5		63.5
8MXT	8MXT-XTP	1/2		12.7	0.81		20.6	4000		27.6	16000		110.3	2.8		71.1
10MXT	10MXT-XTP	5/8		15.9	0.95		24.1	3625		25	14500		100	3.0		76.2
12MXT	12MXT-XTP	3/4		19.0	1.08		27.4	3125		21.6	12500		86.2	4.8		121.9
16MXT	16MXT-XTP	1		25.4	1.38		35.1	2400		16.6	9600		66.2	6.0		152.4

M6K Mega6000® / 6000 psi

2层钢丝编织管

标准	ISO 18752 Grade B
内胶层	黑色耐油合成橡胶 (C类丁腈橡胶)。
增强层	2层高强度钢丝编织。
标准外层	黑色耐油合成橡胶 (C2类改性丁腈橡胶), 橙色标签。
XTF耐磨外层	XtraTuff 适用于有摩擦的工况, XTF外胶比标准胶管外胶耐磨25倍。
MTF耐磨外层	MegaTuff 适用于频繁摩擦的工况, MTF外胶比标准胶管耐磨300倍。
温度范围	-40°C至+100°C, 其它介质请参考温度限值表。
适配接头	一体式G系列。



订货型号

标准管	XTF耐磨管	MTF耐磨管	inch		mm	inch		mm	psi		Mpa	psi		Mpa	inch		mm
4M6K	4M6K-XTF	4M6K-MTF	1/4		6.3	0.54		13.7	5000		34.5	20000		137.9	2.0		50.8

M5K Mega5000® / 5000 psi

2层钢丝编织管

标准	ISO 18752 Grade B
内胶层	黑色耐油合成橡胶 (C类丁腈橡胶)。
增强层	2层高强度钢丝编织。
标准外胶层	黑色耐油合成橡胶 (C2类改性丁腈橡胶), 红色标签。
XTF耐磨外胶层	XtraTuff 适用于有摩擦的工况, XTF外胶比标准胶管外胶耐磨25倍。
MTF耐磨外胶层	MegaTuff 适用于频繁摩擦的工况, MTF外胶比标准胶管耐磨300倍。
温度范围	-40°C至+100°C, 其它介质请参考温度限值表。
适配接头	一体式G系列。



订货型号

标准管	XTF耐磨管	MTF耐磨管	inch	mm	inch	mm	psi	Mpa	psi	Mpa	inch	mm
4M5K	4M5K-XTF	4M5K-MTF	1/4	6.3	0.54	13.7	5000	34.5	20000	137.9	2.0	50.8
5M5K	5M5K-XTF	5M5K-MTF	5/16	7.9	0.61	15.5	5000	34.5	20000	137.9	2.2	55.9
6M5K	6M5K-XTF	6M5K-MTF	3/8	9.5	0.69	17.5	5000	34.5	20000	137.9	2.5	63.5
8M5K	8M5K-XTF	8M5K-MTF	1/2	12.5	0.86	21.8	5000	34.5	20000	137.9	3.5	88.9

M4K Mega4000® / 4000 psi

SAE 100 R19 2层钢丝编织管

标准	SAE100R19、ISO 18752 Grade B
内胶层	黑色耐油合成橡胶 (C类丁腈橡胶)。
增强层	2层高强度钢丝编织。
标准外胶层	黑色耐油合成橡胶 (C2类改性丁腈橡胶)。紫色标签。
XTF耐磨外胶层	XtraTuff 适用于有摩擦的工况, XTF外胶比标准胶管外胶耐磨25倍。
MTF耐磨外胶层	MegaTuff 适用于频繁摩擦的工况, MTF外胶比标准胶管耐磨300倍。
温度范围	-40°C至+100°C, 其它介质请参考温度限值表。
适配接头	一体式G系列 (-16分体式GS系列)。



订货型号

标准管	XTF耐磨管	MTF耐磨管	inch	mm	inch	mm	psi	Mpa	psi	Mpa	inch	mm
4M4K	4M4K-XTF	4M4K-MTF	1/4	6.3	0.54	12.2	4000	28.0	16000	110.0	1.5	38.1
5M4K	5M4K-XTF	5M4K-MTF	5/16	7.9	0.61	15.1	4000	28.0	16000	110.0	1.8	45.7
6M4K	6M4K-XTF	6M4K-MTF	3/8	9.5	0.69	16.0	4000	28.0	16000	110.0	2.0	50.8
8M4K	8M4K-XTF	8M4K-MTF	1/2	12.5	0.86	20.2	4000	28.0	16000	110.0	2.8	71.1
10M4K	10M4K-XTF	10M4K-MTF	5/8	15.9	0.98	25.2	4000	28.0	16000	110.0	3.0	76.2
12M4K	12M4K-XTF	12M4K-MTF	3/4	19.1	1.14	29.1	4000	28.0	16000	110.0	3.8	96.5
16M4K	16M4K-XTF	16M4K-MTF	1	25.4	1.52	37.6	4000	28.0	16000	110.0	4.5	114.3

M3K Mega3000® / 3250 psi

SAE 100 R17 1-2 层钢丝编织管

标准	SAE100R17, ISO 18752 Grade B"
内胶层	黑色耐油合成橡胶 (C类丁腈橡胶)
增强层	1-2层高强度钢丝编织 (-3 -4 -5 -6 -8为1层钢丝, -10及以上规格为2层钢丝)。
标准外胶层	黑色耐油合成橡胶 (C2类改性丁腈橡胶), 蓝色标签。
XTF耐磨外胶层	XtraTuff 适用于有摩擦的工况, XTF外胶比标准胶管外胶耐磨25倍。
MTF耐磨外胶层	MegaTuff 适用于频繁摩擦的工况, MTF外胶比标准胶管耐磨300倍。
温度范围	-40°C至+100°C, 其它介质请参考温度限值表。
适配接头	一体式G系列。



订货型号

标准管	XTF耐磨管	MTF耐磨管	inch	mm	inch	mm	psi	Mpa	psi	Mpa	inch	mm
3M3K	3M3K-XTF	3M3K-MTF	3/16	4.8	0.43	10.8	3250	22.5	13000	90.0	1.3	33.0
4M3K	4M3K-XTF	4M3K-MTF	1/4	6.3	0.48	12.2	3250	22.5	13000	90.0	1.5	38.1
5M3K	5M3K-XTF	5M3K-MTF	5/16	7.9	0.60	15.1	3250	22.5	13000	90.0	1.8	45.7
6M3K	6M3K-XTF	6M3K-MTF	3/8	9.5	0.63	16.0	3250	22.5	13000	90.0	2.0	50.8
8M3K	8M3K-XTF	8M3K-MTF	1/2	12.5	0.80	20.2	3250	22.5	13000	90.0	2.8	71.1
10M3K	10M3K-XTF	10M3K-MTF	5/8	15.9	0.99	25.2	3250	22.5	13000	90.0	3.0	76.2
12M3K	12M3K-XTF	12M3K-MTF	3/4	19.1	1.15	29.1	3250	22.5	13000	90.0	3.8	96.5
16M3K	16M3K-XTF	16M3K-MTF	1	25.4	1.56	37.6	3250	22.5	13000	90.0	4.5	114.3

G1

SAE 100 R1 1 层钢丝编织管

标准	SAE100R1, EN853 1SN
内胶层	黑色耐油合成橡胶 (C类丁腈橡胶)。
增强层	1层高强度钢丝编织。
外胶层	黑色耐油合成橡胶 (C2类改性丁腈橡胶)。
温度范围	-40°C至+100°C, 其它介质请参考温度限值表。
适配接头	G、GSP系列, (-4至-20) 一体式G系列, (-24及以上) 分体式GSP系列。



订货型号	inch	mm	inch	mm	psi	Mpa	psi	Mpa	inch	mm
3G1	3/16	4.8	0.47	11.9	3625	25.0	14500	100.0	3.0	76.2
4G1	1/4	6.3	0.53	13.5	3275	22.6	13100	90.3	4.0	101.6
5G1	5/16	7.9	0.59	15.0	3125	21.5	12500	86.2	4.5	114.3
6G1	3/8	9.5	0.69	17.5	2600	17.9	10400	71.7	5.0	127.0
8G1	1/2	12.5	0.82	20.8	2325	16.0	9300	64.1	7.0	177.8
10G1	5/8	15.9	0.94	23.9	1900	13.1	7600	52.4	8.0	203.2
12G1	3/4	19.1	1.10	27.9	1525	10.5	6100	42.1	9.0	228.6
16G1	1	25.4	1.41	35.8	1275	8.8	5100	35.2	12.0	304.8
20G1	1 1/4	31.8	1.71	43.4	925	6.4	3700	25.5	16.0	406.4
24G1	1 1/2	38.1	1.96	49.8	725	5.0	2900	20.0	20.0	508.0
32G1	2	50.8	2.52	64.0	600	4.1	2400	16.5	25.0	635.0
40G1	2 1/2	63.5	3.09	78.5	375	2.6	1500	10.4	30.0	762.0
48G1	3	76.0	3.50	89.0	325	2.2	1300	8.8	33.0	838.2

G2

**SAE 100 R2
2层钢丝编织管**

标准	SAE100R2, EN853 2SN
内胶层	黑色耐油合成橡胶 (C类丁腈橡胶)。
增强层	2层高强度钢丝编织。
外胶层	黑色耐油合成橡胶 (C2类改性丁腈橡胶)。
温度范围	-40°C至+100°C, 其它介质请参考温度限值表。
适配接头	G、GSP系列, (-4至-20 一体式G系列, (-24及以上)分体式GSP系列。



订货型号	inch		mm	inch		mm	psi		Mpa	psi		Mpa	inch		mm
3G2	3/16		4.8	0.52		13.2	6000		41.4	24000		165.5	3.5		88.9
4G2	1/4		6.3	0.58		14.7	5800		40.0	23200		160.0	4.0		101.6
6G2	3/8		9.5	0.73		18.5	4800		33.1	19200		132.4	5.0		127.0
8G2	1/2		12.5	0.86		21.8	4000		27.6	16000		110.3	7.0		177.8
10G2	5/8		15.9	0.98		24.9	3625		25.0	14500		100.0	8.0		203.2
12G2	3/4		19.1	1.14		29.0	3100		21.4	12400		85.5	9.5		241.3
16G2	1		25.4	1.48		37.6	2400		16.5	9600		66.2	12.0		304.8
20G2	1 1/4		31.8	1.87		47.5	1825		12.6	7300		50.3	16.5		419.1
24G2	1 1/2		38.1	2.15		54.6	1300		9.0	5200		35.9	20.0		508.0
32G2	2		50.8	2.65		67.3	1175		8.1	4700		32.4	25.0		635.0

CR1

**SAE 100 R1
1层钢丝编织管**

标准	SAE100R1, EN853 1SN
内胶层	黑色, 耐油的合成橡胶(C类丁腈橡胶)。
增强层	1层高强度钢丝编织。
外胶层	黑色、耐磨的合成橡胶(丁苯橡胶)。
温度范围	-40°F ~ +212°F (-40°C ~ +100°C)
适配接头	全系列G系列



订货型号	inch		mm	inch		mm	psi		Mpa	psi		Mpa	inch		mm
4CR1	1/4		6.4	0.52		13.2	3275		22.6	13100		90.3	4.0		101.6
5CR1	5/16		7.9	0.59		15.0	3125		21.6	12500		86.2	4.5		114.3
6CR1	3/8		9.5	0.66		16.8	2600		17.9	10400		71.7	5.0		127.0
8CR1	1/2		12.7	0.78		19.8	2325		16.0	9300		64.1	7.0		177.8
10CR1	5/8		15.9	0.91		23.2	1900		13.1	7600		52.4	8.0		203.2
12CR1	3/4		19.1	1.07		27.1	1525		10.5	6100		42.1	9.5		241.3
16CR1	1		25.4	1.38		35	1250		8.6	5000		34.5	11.8		299.7

CR2

**SAE 100 R2
2层钢丝编织管**

标准	SAE100R2, EN853 2SN
内胶层	黑色, 耐油的合成橡胶(C类丁腈橡胶)
增强层	2层高强度钢丝编织。
外胶层	黑色耐油合成橡胶
温度范围	-40°F ~ +212°F (-40°C ~ +100°C)
适配接头	全系列G系列



订货型号	inch		mm	inch		mm	psi		Mpa	psi		Mpa	inch		mm
4CR2	1/4		6.4	0.57		14.5	5800		40.0	23200		160	4.0		101.6
5CR2	5/16		7.9	0.64		16.3	5000		34.5	20000		137.9	4.5		114.3
6CR2	3/8		9.5	0.73		18.5	4800		33.1	19200		132.4	5.0		127.0
8CR2	1/2		12.7	0.85		21.6	4000		27.6	16000		110.3	7.0		177.8
10CR2	5/8		15.9	0.98		24.9	3625		25.0	14500		100	8.0		203.2
12CR2	3/4		19.1	1.14		29	3125		21.5	12500		86.2	9.5		241.3
16CR2	1		25.4	1.46		37.1	2400		16.5	9600		66.2	11.8		299.7

M2T MegaFlex®

**SAE 100 R16
2层钢丝编织管**

标准	SAE100R16, EN857 2SC
内胶层	黑色耐油合成橡胶(C类丁腈橡胶)。
增强层	2层高强度钢丝编织。
标准外胶层	黑色耐油合成橡胶(C2类改性丁腈橡胶), 绿色标签。
XTF耐磨外胶层	XtraTuff, 适用于有摩擦的工况, XTF外胶比标准胶管外胶耐磨25倍。
MTF耐磨外胶层	MegaTuff, 适用于频繁摩擦的工况, MTF外胶比标准胶管耐磨300倍。
温度范围	-40°C至+100°C, 其它介质请参考温度限值表。
适配接头	G、GSP系列, (-4至-20)一体式G系列, (-24及以上)分体式GSP系列。



订货型号

标准管	XTF耐磨管	MTF耐磨管	inch		mm	inch		mm	psi		Mpa	psi		Mpa	inch		mm
4M2T	4M2T-XTF	4M2T-MTF	1/4		6.3	0.54		12.2	6000		41.4	24000		165.5	1.5		38.1
5M2T	5M2T-XTF	5M2T-MTF	5/16		7.9	0.60		15.1	5500		37.9	22000		151.7	1.8		45.7
6M2T	6M2T-XTF	6M2T-MTF	3/8		9.5	0.69		16.0	5000		34.5	20000		137.9	2.0		50.8
8M2T	8M2T-XTF	8M2T-MTF	1/2		12.5	0.82		20.2	4300		29.6	17200		118.6	2.8		71.1
10M2T	10M2T-XTF	10M2T-MTF	5/8		15.9	0.95		25.2	3800		26.2	15200		104.8	3.0		76.2
12M2T	12M2T-XTF	12M2T-MTF	3/4		19.1	1.10		29.1	3500		24.1	14000		96.5	3.8		96.5
16M2T	16M2T-XTF	16M2T-MTF	1		25.4	1.38		37.6	2500		17.2	10000		68.9	4.5		114.3
20M2T	20M2T-XTF	—	1 1/4		31.8	1.67		42.4	2300		15.9	9200		63.4	8.3		210.8
24M2T	24M2T-XTF	—	1 1/2		38.1	2.00		50.8	2000		13.8	8000		55.2	10.0		254.0
32M2T	32M2T-XTF	—	2		50.8	2.53		64.3	1500		10.3	6000		41.4	12.5		317.5

MXG™ 5K 软管



标准	ISO 18752 350DC, 100R13, EN856 R13, ISO 3862 R13
结构	黑色耐油合成内胶, 两层高强度钢丝编织的增强层
外胶	标配黑色XtraTuff™ Plus 2耐磨、耐臭氧合成橡胶, 比标准胶管外胶耐磨25倍, 满足MSHA阻燃标准
温度范围	-40°C至+121°C
适配接头	分体式GS系列接头

描述	inch	mm	inch	mm	psi	Mpa	psi	Mpa	inch	mm
6MXG 5K	3/8	9.5	0.71	18.0	5076	35.0	20300	140.0	2.5	63.5
8MXG 5K	1/2	12.7	0.85	21.6	5076	35.0	20300	140.0	3.5	88.9
10MXG 5K	5/8	15.9	1.03	26.1	5076	35.0	20300	140.0	3.9	99.1
12MXG 5K	3/4	19.0	1.16	29.6	5076	35.0	20300	140.0	4.7	119.4
16MXG 5K	1	25.4	1.52	38.7	5076	35.0	20300	140.0	5.9	149.9

MXG™ 4K 软管



标准	ISO 18752 280DC ISO 18752, SAE 100R19, SAE 100R12, EN 856 R12和 ISO 3862 R12
结构	黑色耐油合成内胶; 两层高强度钢丝编织的增强层
外胶	标配黑色XtraTuff™ Plus 2耐磨、耐臭氧合成橡胶, 比标准胶管外胶耐磨25倍, 满足MSHA阻燃标准
温度范围	-40°C至+121°C
适配接头	分体式GS系列接头

描述	inch	mm	inch	mm	psi	Mpa	psi	Mpa	inch	mm
6MXG 4K	3/8	9.5	0.70	17.7	4060	28.0	16240	112.0	2.5	63.5
8MXG 4K	1/2	12.7	0.82	20.7	4060	28.0	16240	112.0	3.5	88.9
10MXG 4K	5/8	15.9	0.99	25.2	4060	28.0	16240	112.0	3.9	99.1
12MXG 4K	3/4	19.0	1.14	28.9	4060	28.0	16240	112.0	4.7	119.4
16MXG 4K	1	25.4	1.50	38.0	4060	28.0	16240	112.0	5.9	149.9

G8K / 8000 psi

6层钢丝缠绕管

标准	ISO18752
内胶层	黑色耐油合成橡胶(聚氯丁橡胶)
增强层	6层高强度钢丝交替缠绕
外胶层	黑色耐油合成橡胶(A类氯丁橡胶), 黄色标签
温度范围	-40°C至+121°C, 其它介质请参考温度限值表
适配接头	G8K-专用接头



订货型号	inch	mm	inch	mm	psi	Mpa	psi	Mpa	inch	mm
12G8K	3/4	19.1	2.26	57.40	8000	55.2	32000	220.8	9.5	241.3
16G8K	1	25.4	2.80	71.12	8000	55.2	32000	220.8	12.0	304.8

EFG6K / 6000 psi

SAE 100 R15 4-6层钢丝缠绕管

标准	SAE100R15, ISO18752 Grade D
内胶层	黑色耐油合成橡胶(C类丁腈橡胶)
增强层	4-6层高强度钢丝交替缠绕(-6至-16为4层, -20及以上规格为6层)
标准外胶层	黑色耐油合成橡胶(A类氯丁橡胶), 橙色标签
MTF耐磨外胶层	MegaTuff 适用于频繁摩擦的工况且无需使用弹簧或尼龙护套, 超强的耐臭氧、紫外线及老化性能, 按照ISO 6945耐磨测试标准, MTF外胶比标准胶管外胶耐磨300倍。
温度范围	-40°C至+121°C, 其它介质请参考温度限值表
适配接头	-6~-20 GS系列 -24及以上, GSM系列



订货型号	标准管	MTF耐磨管	inch	mm	inch	mm	psi	Mpa	psi	Mpa	inch	mm
6EFG6K	6EFG6K-MTF	3/8	9.5	0.80	20.3	6000	41.4	24000	165.5	2.5	63.5	
8EFG6K	8EFG6K-MTF	1/2	12.7	0.95	24.1	6000	41.4	24000	165.5	3.5	88.9	
10EFG6K	10EFG6K-MTF	5/8	15.9	1.09	27.7	6000	41.4	24000	165.5	4.0	101.6	
12EFG6K	12EFG6K-MTF	3/4	19.1	1.24	31.5	6000	41.4	24000	165.5	4.8	121.9	
16EFG6K	16EFG6K-MTF	1	25.4	1.53	38.9	6000	41.4	24000	165.5	6.0	152.4	
20EFG6K	20EFG6K-MTF	1 1/4	31.8	1.97	50.0	6000	41.4	24000	165.5	8.2	208.3	
24EFG6K	24EFG6K-MTF	1 1/2	38.1	2.26	57.4	6000	41.4	24000	165.5	10.0	254.0	
32EFG6K	32EFG6K-MTF	2	50.8	2.80	71.1	6000	41.4	24000	165.5	25.0	635.0	

EFG5K / 5000 psi

SAE 100 R13 4-6层钢丝缠绕管

标准	SAE100R13, ISO18752 Grade D
内胶层	黑色耐油合成橡胶(C类丁腈橡胶)
增强层	4-6层高强度钢丝交替缠绕(-6至-16为4层,-20及以上规格为6层)。
标准外胶层	黑色耐油合成橡胶(A类氯丁橡胶), 红色标签
MTF耐磨外胶层	MegaTuff 适用于频繁摩擦的工况且无需使用弹簧或尼龙护套, 超强的耐臭氧、紫外线及老化性能, 按照ISO 6945耐磨测试标准, MTF外胶比标准胶管外胶耐磨300倍
温度范围	-40°C至+121°C, 其它介质请参考温度限值表
适配接头	-6~-20 GS系列 -24及以上, GSM系列



订货型号

标准管	MTF耐磨管	inch	mm	inch	mm	psi	Mpa	psi	Mpa	inch	mm
6EFG5K	6EFG5K-MTF	3/8	9.5	0.80	20.3	5000	34.5	20000	137.9	2.5	63.5
8EFG5K	8EFG5K-MTF	1/2	12.7	0.95	24.1	5000	34.5	20000	137.9	3.5	88.9
10EFG5K	10EFG5K-MTF	5/8	15.9	1.09	27.7	5000	34.5	20000	137.9	4.0	101.6
12EFG5K	12EFG5K-MTF	3/4	19.1	1.24	31.5	5000	34.5	20000	137.9	4.8	121.9
16EFG5K	16EFG5K-MTF	1	25.4	1.53	38.9	5000	34.5	20000	137.9	6.0	152.4
20EFG5K	20EFG5K-MTF	1 1/4	31.8	1.97	50.0	5000	34.5	20000	137.9	8.2	210.8
24EFG5K	24EFG5K-MTF	1 1/2	38.1	2.26	57.4	5000	34.5	20000	137.9	10.0	254.0
32EFG5K	32EFG5K-MTF	2	50.8	2.80	71.1	5000	34.5	20000	137.9	25.0	635.0
40EFG5K	40EFG5K-MTF	2 1/2	63.5	3.35	85.1	5000	34.5	20000	137.9	30.0	762.0

EFG4K / 4000 psi

SAE 100 R12 4-6层钢丝缠绕管

标准	SAE100R12, ISO18752 Grade D
内胶层	黑色耐油合成橡胶(C类丁腈橡胶)
增强层	4-6层高强度钢丝交替缠绕(-6至-20为4层,-48为6层)
标准外胶层	黑色耐油合成橡胶(A类氯丁橡胶), 紫色标签
MTF耐磨外胶层	MegaTuff 适用于频繁摩擦的工况且无需使用弹簧或尼龙护套, 超强的耐臭氧、紫外线及老化性能, 按照ISO 6945耐磨测试标准, MTF外胶比标准胶管外胶耐磨300倍
温度范围	-40°C至+121°C, 其它介质请参考温度限值表。
适配接头	-6~-20 GS系列 -24及以上, GSM系列



订货型号

标准管	MTF耐磨管	inch	mm	inch	mm	psi	Mpa	psi	Mpa	inch	mm
6EFG4K	6EFG4K-MTF	3/8	9.5	0.80	20.3	4000	27.6	16000	110.3	2.5	63.5
8EFG4K	8EFG4K-MTF	1/2	12.7	0.94	24.1	4000	27.6	16000	110.3	3.5	88.9
10EFG4K	10EFG4K-MTF	5/8	15.9	1.09	27.7	4000	27.6	16000	110.3	4.0	101.6
12EFG4K	12EFG4K-MTF	3/4	19.1	1.21	30.7	4000	27.6	16000	110.3	4.8	121.9
16EFG4K	16EFG4K-MTF	1	25.4	1.50	38.1	4000	27.6	16000	110.3	6.0	152.4
20EFG4K	20EFG4K-MTF	1 1/4	31.8	1.85	47.0	4000	27.6	16000	110.3	8.3	210.8
48EFG4K	48EFG4K-MTF	3	76.2	3.86	98.0	4000	27.6	16000	110.3	35	889.0

EFG3K / 3000 psi

SAE 100 R12 4层钢丝缠绕管

标准	SAE100R12, ISO 18752 Grade D
内胶层	黑色耐油合成橡胶(C类丁腈橡胶)
增强层	4层高强度钢丝交替缠绕
标准外胶层	黑色耐油合成橡胶(A类丁腈橡胶), 蓝色标签
MTF耐磨外胶层	MegaTuff 适用于频繁摩擦的工况且无需使用弹簧或尼龙护套, 超强的耐臭氧、紫外线及老化性能, 按照ISO 6945耐磨测试标准, MTF外胶比标准胶管外胶耐磨300倍
温度范围	-40°C至+121°C, 其它介质请参考温度限值表
适配接头	-20, GS系列 -24, -32 GSP系列



订货型号

标准管	MTF耐磨管	inch	mm	inch	mm	psi	Mpa	psi	Mpa	inch	mm
20EFG3K	20EFG3K-MTF	1 1/4	31.8	1.85	47.0	3000	20.7	12000	82.7	8.3	210.8
24EFG3K	24EFG3K-MTF	1 1/2	38.1	2.11	53.6	3000	20.7	12000	82.7	10.0	254.0
32EFG3K	32EFG3K-MTF	2	50.8	2.63	66.8	3000	20.7	12000	82.7	25.0	635.0

4XP

EN856 4SP 4层钢丝缠绕管

标准	EN856 4SP
内胶层	黑色耐油合成橡胶(丁腈橡胶)
增强层	4层高强度钢丝缠绕
外胶层	黑色耐油合成橡胶(丁腈橡胶)
温度范围	-40°C至+100°C, 其它介质请参考温度限值表
适配接头	分体式GS系列







订货型号	inch	mm	inch	mm	psi	Mpa	psi	Mpa	inch	mm
6-4XP	3/8	9.5	0.83	21.1	6650	45.9	26600	183.4	4.3	109.2
8-4XP	1/2	12.5	0.96	24.4	6150	42.4	24600	169.6	4.7	119.4
10-4XP	5/8	15.9	1.09	27.7	5800	40.0	23200	160.0	5.5	139.7
12-4XP	3/4	19.1	1.24	31.5	5500	37.9	22000	151.7	6.7	170.2
16-4XP	1	25.4	1.54	39.1	4650	32.1	18600	128.2	13.4	340.4
20-4XP	1 1/4	31.8	1.96	49.8	3050	21.0	12200	84.1	18.1	459.7

4XH

EN856 4SH 4层钢丝缠绕管

标准	EN856 4SH
内胶层	黑色耐油合成橡胶(丁腈橡胶)
增强层	4层高强度钢丝缠绕
外胶层	黑色耐油合成橡胶(丁腈橡胶)
温度范围	-40°C至+100°C, 其它介质请参考温度限值表
适配接头	-12~-20 GS系列 -24 GSP系列



订货型号	inch	 mm	inch	 mm	psi	 Mpa	psi	 Mpa	inch	 mm
12-4XH	3/4	19.1	1.24	31.5	6100	42.1	24400	168.2	8.3	210.8
16-4XH	1	25.4	1.48	37.6	5600	38.6	22400	154.4	8.7	221.0
20-4XH	1 1/4	31.8	1.78	45.2	5050	34.8	20200	139.3	16.5	419.1
24-4XH	1 1/2	38.1	1.94	49.3	4205	29.0	16820	116.0	22.0	558.8

MULTI MASTER® GMV™ MEGAFLEX®

吸油、回油、排放专用管

推荐用途	适用于液压返回和吸入管路，输送精炼燃料或其他石油产品，以及冷却剂管路。超柔管需求的位置
标准	SAE 100R4, SAE J30R5和SAE J20R5*(管尺寸除外)
内胶层	C类丁腈橡胶
增强层	2层纤维加螺旋钢丝
外胶层	黑色耐油、耐磨合成橡胶 (A类氯丁橡胶)
温度范围	-40°F ~+275°F (-40°C ~ +135°C)
适配接头	(-12~-20) 一体式G系列, -240~-32以上分体式GSP系列, -40以上GL系列



订货型号	inch	mm	inch	mm	psi	Mpa	psi	Mpa	inch	mm
12GMV	3/4	19.05	1.2	30.48	350	2.41	1400	9.66	0.8	20.3
16GMV	1	25.40	1.41	35.81	300	2.07	1200	8.28	1	25.4
20GMV	1 1/4	31.75	1.66	42.16	250	1.72	1000	6.90	1.3	33.0
24GMV	1 1/2	38.10	1.9	48.26	150	1.03	600	4.14	1.5	38.1
32GMV	2	50.80	2.39	60.71	150	1.03	600	4.14	2	50.8
40GMV	2 1/2	63.50	2.94	74.68	150	1.03	600	4.14	2.5	63.5
48GMV	3	76.20	3.44	87.38	150	1.03	600	4.14	3	76.2
64GMV	4	101.60	4.48	113.79	150	1.03	600	4.14	4	101.6
96GMV	6	152.40	6.55	166.37	150	1.03	600	4.14	6	152.4

J2AT

千斤顶专用管

推荐用途	液压千斤顶用管，符合MHI (Material Handling Institute) IJ100标准，工作压力10000psi仅限于静压
标准	IJ100
内胶层	黑色耐油合成橡胶 (C类丁腈橡胶)
增强层	2层高强度钢丝编织
外胶层	黑色耐油、耐磨合成橡胶 (C2类改性丁腈橡胶)
MTF耐磨外胶层	MegaTuff®适用于频繁摩擦的工况，MTF外胶比标准胶管外胶耐磨300倍
温度范围	-40°C ~ +49°C
适配接头	一体式G-NPTF外螺纹加长专用系列



订货型号	标准管	MTF耐磨管	inch	mm	inch	mm	psi	Mpa	psi	Mpa	inch	mm
4J2AT	4J2AT-MTF		1/4	6.4	0.58	14.7	10000	69.0	40000	275.8	4.0	101.6
6J2AT	6J2AT-MTF		3/8	9.5	0.74	18.8	10000	69.0	40000	275.8	5.0	127.0

LOL / Plus Lock-On

即插免卡箍软管

推荐用途	水、空气、乙二醇防冻液、石油基类液压油、发动机润滑油，未得到盖茨产品应用部门的书面许可禁止用于汽油、柴油介质，即插型接头不得用于有脉冲及危险行业应用，以及住宅或商业建筑永久性管路布置
内胶层	黑色耐油合成橡胶 (C类丁腈橡胶)
增强层	1层纤维织层
外胶层	黑色耐油合成橡胶 (C2类改性丁腈橡胶)，可搭配不同颜色的氯丁橡胶
温度范围	-40°C至+100°C，空气+71°C，水+85°C，其它介质请参考温度限值表
适配接头	专用LOC接头，卡箍



订货型号

黑色	红色	绿色	蓝色	黄色	灰色	inch	mm	inch	mm	psi	Mpa	psi	Mpa	inch	mm
4LOLA	4LOLR	4LOLG	4LOLB	4LOLY	4LOLC	1/4	6.3	0.47	11.9	300	2.1	1200	8.3	3.0	76.2
5LOLA	5LOLR	5LOLG	5LOLB	5LOLY	5LOLC	5/16	7.9	0.55	14.0	300	2.1	1200	8.3	3.0	76.2
6LOLA	6LOLR	6LOLG	6LOLB	6LOLY	6LOLC	3/8	9.5	0.63	16.0	300	2.1	1200	8.3	3.0	76.2
8LOLA	8LOLR	8LOLG	8LOLB	8LOLY	8LOLC	1/2	12.5	0.77	19.6	300	2.1	1200	8.3	5.0	127.0
10LOLA	10LOLR	10LOLG	10LOLB	10LOLY	10LOLC	5/8	15.9	0.94	23.9	300	2.1	1200	8.3	6.0	152.4
12LOLA	12LOLR	12LOLG	12LOLB	12LOLY	12LOLC	3/4	19.1	1.06	26.9	300	2.1	1200	8.3	7.0	177.8

GTH

SAE 100 R6 高温 1层纤维管

标准	SAE100 R6
内胶层	黑色耐油合成橡胶 (C类丁腈橡胶)
增强层	1层纤维织层
外胶层	黑色耐油合成橡胶 (A类氯丁橡胶)
温度范围	-40°C至+135°C，间歇为+149°C (不超过运行时间的10%)，水、空气等其它介质请参考温度限值表
适配接头	G系列接头，卡箍



订货型号	inch	mm	inch	mm	psi	Mpa	psi	Mpa	inch	mm
4GTH	1/4	6.3	0.50	12.7	400	2.8	1600	11.0	2.5	63.5
5GTH	5/16	7.9	0.56	14.2	400	2.8	1600	11.0	3.0	76.2
6GTH	3/8	9.5	0.63	16.0	400	2.8	1600	11.0	3.0	76.2
8GTH	1/2	12.5	0.78	19.8	400	2.8	1600	11.0	4.0	101.6
10GTH	5/8	15.9	0.91	23.1	350	2.4	1400	9.7	5.0	127.0
12GTH	3/4	19.1	1.06	26.9	300	2.1	1200	8.3	5.5	139.7
16GTH	1	25.4	1.13	37.6	250	1.7	1000	6.9	8.0	203.2

RLA

SAE 30 R2 1层纤维管

推荐用途	柴油、汽油、水、空气、乙二醇防冻液、B20生物柴油
内胶层	黑色耐油合成橡胶 (C类丁腈橡胶)
增强层	1层纤维层
外胶层	黑色耐油合成橡胶 (C类丁腈橡胶)
温度范围	-40°C ~ +100°C, 燃油不超过51°C, 空气+71°C, 水+85°C, 其它介质请参考温度限值表
适配接头	G系列接头



订货型号	inch	mm	inch	mm	psi	Mpa	psi	Mpa	inch	mm
4RLA	1/4	6.3	0.50	12.7	250	1.7	1000	6.9	3.0	76.2
5RLA	5/16	7.9	0.56	14.2	250	1.7	1000	6.9	4.0	101.6
6RLA	3/8	9.5	0.66	16.8	250	1.7	1000	6.9	4.0	101.6
8RLA	1/2	12.5	0.81	20.6	200	1.4	800	5.5	5.0	127.0
10RLA	5/8	15.9	0.94	23.9	200	1.4	800	5.5	5.0	127.0
12RLA	3/4	19.1	1.09	27.7	200	1.4	800	5.5	6.0	152.4
16RLA	1	25.4	1.34	34.0	160	1.1	640	4.4	8.0	203.2

G3H

SAE 100 R3 高温 2层纤维管

推荐用途	石油基类液压油、水、空气、乙二醇防冻液
内胶层	黑色耐油合成橡胶 (C类丁腈橡胶)
增强层	2层纤维编织层
外胶层	黑色耐油合成橡胶 (A类氯丁橡胶)
温度范围	-40°C ~ +135°C, 间歇为+149°C (不超过运行时间的10%), 水、空气等其它介质请参考温度限值表
适配接头	(-4至-20) 一体式G系列, -24及分体式GSP系列



订货型号	inch	mm	inch	mm	psi	Mpa	psi	Mpa	inch	mm
4G3H	1/4	6.3	0.56	14.2	1250	8.6	5000	34.5	3.0	76.2
5G3H	5/16	7.9	0.66	16.8	1200	8.3	4800	33.1	3.5	88.9
6G3H	3/8	9.5	0.75	19.1	1125	7.8	4500	31.0	4.0	101.6
8G3H	1/2	12.5	0.94	23.9	1000	6.9	4000	27.6	5.0	127.0
10G3H	5/8	15.9	1.10	27.9	900	6.2	3600	24.8	5.5	139.7
12G3H	3/4	19.1	1.25	31.8	750	5.2	3000	20.7	6.0	152.4
16G3H	1	25.4	1.50	38.1	565	3.9	2260	15.6	8.0	203.2
20G3H	1 1/4	31.8	1.75	44.5	375	2.6	1500	10.3	10.0	254.0
24G3H	1 1/2	38.1	1.94	49.3	300	2.1	1200	8.3	12.0	304.8

TH7 / TH7NC

SAE 100 R7

推荐用途 适用于磷酸酯液压油、水乙二醇、石油合成基液压流体，极小的弯曲半径，耐老化性能强，特适用于低温环境及大温差的环境，推荐用于润滑系统、移动设备、机床、工程机械等

标准	性能超越 SAE100 R7
内胶层	100%无渗透尼龙
增强层	合成纤维
外胶层	标准管:黑色聚氨酯 不导电管:橙色特殊合成聚氨酯,符合SAE100 R7导电率导电率<50微安,75kv/Ft(5分钟)
温度范围	-54°C ~ +93°C
适配接头	-2、-3 接头PCTS -4~-16 G系列接头



订货型号

标准管	不导电管	inch		mm	inch		mm	psi		Mpa	psi		Mpa	inch		mm
2TH7	2TH7NC	1/8		3.2	0.32		8.1	3000		20.7	12000		82.7	0.5		12.7
3TH7	3TH7NC	3/16		4.8	0.41		10.4	3000		20.7	12000		82.7	0.8		20.3
4TH7	4TH7NC	1/4		6.3	0.50		12.7	2750		19.0	11000		75.8	1.3		33.0
5TH7	5TH7NC	5/16		7.9	0.56		14.2	2500		17.2	10000		68.9	1.8		45.7
6TH7	6TH7NC	3/8		9.5	0.64		16.3	2250		15.5	9000		62.1	2.0		50.8
8TH7	8TH7NC	1/2		12.5	0.80		20.3	2000		13.8	8000		55.2	3.0		76.2
12TH7	12TH7NC	3/4		19.1	1.05		26.7	1250		8.6	5000		34.5	5.0		127.0
16TH7	16TH7NC	1		25.4	1.32		33.5	1000		6.9	4000		27.6	10.0		254.0

TH7DL

SAE 100 R7

双联管

推荐用途 适用于磷酸酯液压油、石油合成基液压流体，水乙二醇、气体等，极小的弯曲半径，耐老化性能强，推荐应用于叉车、升降平台等

标准	性能超越 SAE100 R7
内胶层	100% Z型尼龙
增强层	合成纤维
外胶层	黑色聚氨酯
温度范围	-54°C ~ +93°C
适配接头	一体式G系列



订货型号	inch		mm	inch		mm	psi		Mpa	psi		Mpa	inch		mm
4TH7DL	1/4		6.3	0.50		12.7	2750		19.0	11000		75.8	1.3		33.0
5TH7DL	5/16		7.9	0.56		14.2	2500		17.2	10000		68.9	1.8		45.7
6TH7DL	3/8		9.5	0.64		16.3	2250		15.5	9000		62.1	2.0		50.8
8TH7DL	1/2		12.5	0.80		20.3	2000		13.8	8000		55.2	3.0		76.2

TH8 / TH8NC

SAE 100 R8

推荐用途 适用于磷酸酯液压油、水乙二醇、石油、合成基液流流体，极小的弯曲半径，耐老化性能强，特适用于低温环境及大温差的环境，推荐用于润滑系统、移动设备、机床、工程机械等

标准	性能超越 SAE100 R8
内胶层	100%无渗透尼龙
增强层	一层聚酯纤维
外胶层	标准管:黑色聚氨酯 不导电管:橙色特殊合成聚氨酯,符合SAE100 R8 导电率<50微安, 75kv/Ft(5分钟)
温度范围	-54°C ~ +93°C
适配接头	一体式G系列

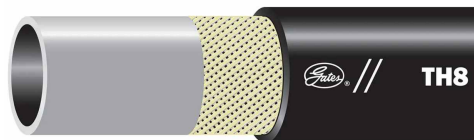

订货型号

标准管	不导电管	inch	mm	inch	mm	psi	Mpa	psi	Mpa	inch	mm
3TH8	-	3/16	4.8	0.50	12.7	5000	34.5	20000	137.9	1.5	38.1
4TH8	4TH8NC	1/4	6.3	0.61	15.5	5000	34.5	20000	137.9	2.0	50.8
6TH8	6TH8NC	3/8	9.5	0.75	19.1	4000	27.6	16000	110.3	2.5	63.5
8TH8	8TH8NC	1/2	12.5	0.87	22.1	3500	24.1	14000	96.5	4.0	101.6
12TH8	-	3/4	19.1	1.13	28.7	2250	15.5	9000	62.1	6.5	165.1
16TH8	-	1	25.4	1.45	36.8	2000	13.8	8000	55.2	10.0	254.0

TH18 / TH18NC

SAE 100 R18

推荐用途 适用于石油、合成基液流流体，极小的弯曲半径，耐老化性能强，特别适用于低温环境及温差大的环境

标准	性能超越 SAE100 R18
内胶层	弹性聚酯
增强层	合成纤维
外胶层	标准管:黑色聚氨酯 不导电管:橙色特殊合成聚氨酯,符合SAE100 R18 导电率<50微安, 75kv/Ft(5分钟)
温度范围	-55°C ~ +100°C
适配接头	一体式G系列



订货型号

标准管	不导电管	inch	mm	inch	mm	psi	Mpa	psi	Mpa	inch	mm
4TH8	4TH18NC	1/4	6.3	0.48	12.2	3000	20.7	12000	82.7	1.4	35.6
5TH8	5TH18NC	5/16	7.9	0.56	14.2	3000	20.7	12000	82.7	1.8	45.7
6TH8	6TH18NC	3/8	9.5	0.65	16.5	3000	20.7	12000	82.7	1.8	45.7
8TH8	8TH18NC	1/2	12.5	0.89	22.6	3000	20.7	12000	82.7	2.8	71.1
10TH8	10TH18NC	5/8	15.9	1.03	26.2	3000	20.7	12000	82.7	3.9	99.1

C14

SAE 100 R14 Type A
不导电特氟龙管

推荐用途	适用于空气压缩机的排放、热油及油脂等
内胶层	A型不导电白色聚四氟乙烯
增强层	1层300系列不锈钢丝编织
温度范围	动态-54°C~+204°C, 静态-54°C~+232°C
适配接头	C14专用系列

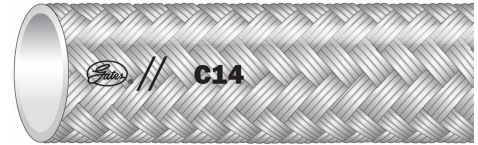

订货型号	inch	mm	inch	mm	psi	Mpa	psi	Mpa	inch	mm
4C14	3/16	4.8	0.31	7.9	1500	10.3	6000	41.4	2.0	50.8
5C14	1/4	6.4	0.38	9.7	1500	10.3	6000	41.4	3.0	76.2
6C14	5/16	7.9	0.45	11.4	1500	10.3	6000	41.4	4.0	101.6
8C14	13/32	10.3	0.55	14.0	1000	6.9	4000	27.6	5.3	134.6
10C14	1/2	12.7	0.65	16.5	800	5.5	3200	22.1	6.5	165.1
12C14	5/8	15.9	0.79	20.1	800	5.5	3200	22.1	7.8	198.1
16C14	7/8	22.2	1.03	26.2	800	5.5	3200	22.1	9.0	228.6

M3KH / 3000 psi

小弯曲半径、恒压
1-2层钢丝编织管

推荐用途	适用于高温环境石油基液压油、聚乙二醇、植物油及水
标准	SAE100 R17, EN857 1SC, ISO 18752 Grade C, 外径小于常规 SAE100 R1、R2胶管
内胶层	黑色耐油合成橡胶 (C类丁腈橡胶)
增强层	1-2层高强度钢丝编织 (-4、-5、-6、-8为1层钢丝, -10及以上规格为2层钢丝)
外胶层	标准外胶层: 黑色耐油合成橡胶 (氯丁橡胶), 蓝色标签。 MTF耐磨外胶层: MegaTuff, 适用于频繁摩擦的工况, MTF外胶比标准胶管外胶耐磨300倍。
温度范围	-40°C~ +121°C, 其它介质请参考温度限值表
适配接头	一体式G系列



订货型号	标准管	MTF耐磨管	inch	mm	inch	mm	psi	Mpa	psi	Mpa	inch	mm
4M3KH	4M3KH-MTF		1/4	6.3	0.48	12.2	3250	22.5	13000	90	1.5	38.1
5M3KH	5M3KH-MTF		5/16	7.9	0.60	15.2	3250	22.5	13000	90	1.8	45.7
6M3KH	6M3KH-MTF		3/8	9.5	0.65	16.5	3250	22.5	13000	90	2.0	50.8
8M3KH	8M3KH-MTF		1/2	12.5	0.80	20.3	3250	22.5	13000	90	2.8	71.1
10M3KH	10M3KH-MTF		5/8	15.9	0.99	25.1	3250	22.5	13000	90	3.0	76.2
12M3KH	12M3KH-MTF		3/4	19.1	1.15	29.2	3250	22.5	13000	90	3.8	96.5
16M3KH	16M3KH-MTF		1	25.4	1.48	37.6	3250	22.5	13000	90	4.5	114.3

MAGETECH G5TB OIL-AIR RETURN

两层编织高温管

推荐用途	涡轮机油高温回油及空气压缩机使用
内胶层	黑色耐温度和耐化学性合成橡胶 (CPE)
增强层	2层高强度钢丝编织
外胶层	蓝色CPE+防油防霉纤维编织
温度范围	石油基介质:-40°F至+300°F(-40°C至+149°C)。磷酸酯介质-40°F至+212°F(-40°C至+100°C)。水乳剂等参考温度限制表
适配接头	G,GSP系列, (-4~-20) 一体式G系列, -20以上分体式GSP系列



订货型号	inch	mm	inch	mm	psi	Mpa	psi	Mpa	inch	mm
4MEGATECH G5TB	1/4	6.35	0.58	14.73	3000	20.69	12000	82.76	2	50.8
6MEGATECH G5TB	3/8	9.53	0.76	19.30	3000	20.69	12000	82.76	2.5	63.5
8MEGATECH G5TB	1/2	12.70	0.87	22.10	3000	20.69	12000	82.76	3.5	88.9
10MEGATECH G5TB	5/8	15.88	0.98	24.89	2000	13.79	8000	55.17	4	101.6
12MEGATECH G5TB	3/4	19.05	1.12	28.45	2000	13.79	8000	55.17	4.7	119.38
16MEGATECH G5TB	1	25.40	1.34	34.04	1000	6.90	4000	27.59	6	152.4
20MEGATECH G5TB	1 1/4	31.75	1.70	43.18	1000	6.90	4000	27.59	8.5	215.9
24MEGATECH G5TB	1 1/2	38.10	1.94	49.28	500	3.45	2000	13.79	9.5	241.3
32MEGATECH G5TB	2	50.80	2.53	64.26	500	3.45	2000	13.79	10.5	266.7

MAGETECH 1000 OIL RETURN

高温回油管、制动管

推荐用途	空气制动软管, 加压热油回油管和旋转油/空气压缩机管路。 满足DOT FMVSS 106-74, SAE J1402对空气制动软管(-4, -6, -8, -10)的要求。不建议用于汽油或柴油燃料应用
内胶层	黑色耐温度和耐化学性合成橡胶 (CPE)
增强层	1层高强度钢丝编织
外胶层	“黑丝CPE外胶+防油防霉纤维编织
温度范围	石油基介质:-40°F至+300°F(-40°C至+149°C)。磷酸酯介质-40°F至+212°F(-40°C至+100°C)。水乳剂等参考温度限制表
适配接头	G系列



订货型号	inch	mm	inch	mm	psi	Mpa	psi	Mpa	inch	mm
4MEGATECH 1000	1/4	6.35	0.52	13.21	1000	6.90	4000	27.59	2	50.8
6MEGATECH 1000	3/8	9.53	0.66	16.76	1000	6.90	4000	27.59	2.5	63.5
8MEGATECH 1000	1/2	12.70	0.8	20.32	1000	6.90	4000	27.59	3.5	88.9
10MEGATECH 1000	5/8	15.88	0.93	23.62	1000	6.90	4000	27.59	4	101.6
12MEGATECH 1000	3/4	19.05	1.15	29.21	1000	6.90	4000	27.59	4.7	119.4
16MEGATECH 1000	1	25.40	1.37	34.80	1000	6.90	4000	27.59	6	152.4
20MEGATECH 1000	1 1/4	31.75	1.68	42.67	1000	6.90	4000	27.59	8.5	215.9

G1H

SAE 100 R1 Type AT 1层钢丝编织高温管

推荐用途	适用于高温石油基液压油、水及乳化液
标准	性能超越SAE100 R1 Type AT, 满足EN45545-2
内胶层	黑色耐油合成橡胶(C类丁腈橡胶)
增强层	1层高强度钢丝编织
外胶层	黑色耐油耐磨合成橡胶(M类-CSM)
温度范围	-40°C至+135°C, 间歇为+149°C (不超过运行时间的10%), 水、空气等其它介质请参考温度限值表
适配接头	G、GSP系列, (-4至-20) 一体式G系列, (-24及以上) 分体式GSP系列



订货型号	inch		mm	inch		mm	psi		Mpa	psi		Mpa	inch		mm
4G1H	1/4		6.3	0.53		13.5	2750		19.0	11000		75.8	4.0		101.6
6G1H	3/8		9.5	0.69		17.5	2250		15.5	10400		71.7	5.0		127.0
8G1H	1/2		12.5	0.80		20.8	2000		13.8	9300		64.1	7.0		177.8
10G1H	5/8		15.9	0.94		23.9	1500		10.3	7600		52.4	8.0		203.2
12G1H	3/4		19.1	1.10		27.9	1250		8.6	6100		42.1	9.5		241.3
16G1H	1		25.4	1.41		35.8	1000		6.9	5100		35.2	12.0		304.8
20G1H	1 1/4		31.8	1.71		43.4	925		6.4	3700		25.5	16.0		406.4
24G1H	1 1/2		38.1	1.96		49.8	725		5.0	2900		20.0	20.0		508.0
32G1H	2		50.8	2.51		64	600		4.1	2400		16.5	25.0		635.0

G2XH

SAE 100 R2 Type S 2层钢丝编织高温管

推荐用途	适用于高温石油基、磷酸酯基液压油、水及乳化液
标准	性能超越SAE100 R2 Type S, 满足EN45545-2
内胶层	黑色耐油、耐化学品合成橡胶(CPE)
增强层	2层高强度钢丝编织
外胶层	蓝色耐油耐磨合成橡胶(CSM)
温度范围	-40°C至+149°C, 磷酸酯液压、水、空气等其它介质请参考温度限值表
适配接头	G、GSP系列, (-4至-20) 一体式G系列, (-24及以上) 分体式GSP系列



订货型号	inch		mm	inch		mm	psi		Mpa	psi		Mpa	inch		mm
4G2XH	1/4		6.3	0.59		15.0	6000		41.4	24000		165.5	4.0		101.6
6G2XH	3/8		9.5	0.74		18.8	5000		34.5	20000		137.9	5.0		127.0
8G2XH	1/2		12.5	0.86		21.8	4250		29.3	17000		117.2	7.0		177.8
10G2XH	5/8		15.9	0.99		25.1	3625		25.0	14500		100.0	8.0		203.2
12G2XH	3/4		19.1	1.15		29.2	3100		21.4	12400		85.5	9.5		241.3
16G2XH	1		25.4	1.48		37.6	2500		17.2	10000		68.9	12.0		304.8
20G2XH	1 1/4		31.8	1.86		47.2	2250		15.5	9000		62.1	16.5		419.1
24G2XH	1 1/2		38.1	2.15		54.6	1800		12.4	7200		49.6	20.0		508.0
32G2XH	2		50.8	2.65		67.3	1500		10.3	6000		41.4	25.0		635.0

M4KH

**SAE 100R19
2层钢丝编织高温管**

标准	SAE 100R19 满足EN45545-2
内胶层	黑色耐油合成内胶
增强层	两层高强度钢丝编织
外层胶	黑色、耐油、耐化学品的合成橡胶, 阻燃强度达到美国MSHA 2G标准, 参考M3KH参数, 紫色外胶
温度范围	-40°C ~ +121°C
适配接头	一体式G系列接头



标准管	MTF耐磨管	inch	mm	inch	mm	psi	Mpa	psi	Mpa	inch	mm
4M4KH X50FT	4M4KH-MTF X50FT	1/4	6.35	0.55	13.97	4000	27.59	16000	110.3	2.0	50.8
4M4KH XREEL	4M4KH-MTF REEL	1/4	6.35	0.55	13.97	4000	27.59	16000	110.3	2.0	50.8
6M4KH X50FT	6M4KH-MTF X50FT	3/8	9.5	0.70	17.78	4000	27.59	16000	110.3	2.5	63.5
6M4KH XREEL	6M4KH-MTF REEL	3/8	9.5	0.70	17.78	4000	27.59	16000	110.3	2.5	63.5
8M4KH X50FT	8M4KH-MTF X50FT	1/2	12.5	0.82	20.83	4000	27.59	16000	110.3	3.5	88.9
8M4KH XREEL	8M4KH-MTF REEL	1/2	12.5	0.82	20.83	4000	27.59	16000	110.3	3.5	88.9
10M4KH X50FT	10M4KH-MTF X50FT	5/8	15.9	0.99	25.15	4000	27.59	16000	110.3	4.0	101.6
10M4KH XREEL	10M4KH-MTF REEL	5/8	15.9	0.99	25.15	4000	27.59	16000	110.3	4.0	101.6
12M4KH X50FT	12M4KH-MTF X50FT	3/4	19.1	1.17	29.72	4000	27.59	16000	110.3	4.7	119.9
12M4KH XREEL	12M4KH-MTF REEL	3/4	19.1	1.17	29.72	4000	27.59	16000	110.3	4.7	119.9

M4KL / 4000 psi

小半弯曲径、恒压
2层钢丝编织管

推荐用途	适用于低温环境石油基液压油、聚乙二醇、植物油及水，极小的弯曲半径更易于管线的布置
内胶层	黑色耐油合成橡胶 (C类丁腈橡胶)
增强层	2层高强度钢丝编织
外胶层	黑色耐油合成橡胶 (A类氯丁橡胶)
温度范围	-57°C ~ +100°C, 其它介质请参考温度限值表
适配接头	-4~-12 G系列接头 -16 GS系列



订货型号	inch	mm	inch	mm	psi	Mpa	psi	Mpa	inch	mm
4M4KL	1/4	6.3	0.54	13.72	4000	28	16000	110	2.0	50.8
5M4KL	5/16	7.9	0.60	15.24	4000	28	16000	110	2.3	58.4
6M4KL	3/8	9.5	0.69	17.53	4000	28	16000	110	2.5	63.5
8M4KL	1/2	12.5	0.82	20.83	4000	28	16000	110	3.5	88.9
10M4KL	5/8	15.9	0.98	24.89	4000	28	16000	110	4.0	101.6
12M4KL	3/4	19.1	1.16	29.46	4000	28	16000	110	6.0	152.4
16M4KL	1	25.4	1.52	38.61	4000	28	16000	110	6.0	152.4

G2L PolarFlex

2层钢丝编织管

推荐用途	适用于低温环境石油基液压油、聚乙二醇、植物油及水
内胶层	黑色耐油耐磨合成橡胶 (C类丁腈橡胶)
增强层	2层高强度钢丝编织
外胶层	黑色耐油合成橡胶 (A类氯丁橡胶)
温度范围	-57°C ~ +100°C, 其它介质请参考温度限值表
适配接头	G、GSP系列, (-4至-20) 一体式G系列, (-24及以上) 分体式GSP系列



订货型号	inch	mm	inch	mm	psi	Mpa	psi	Mpa	inch	mm
4G2L	1/4	6.3	0.59	15.0	5800	40.0	23200	160.0	4.0	101.6
6G2L	3/8	9.5	0.74	18.8	4800	33.1	19200	132.4	5.0	127.0
8G2L	1/2	12.5	0.86	21.8	4000	27.6	16000	110.3	7.0	177.8
10G2L	5/8	15.9	0.99	25.1	3625	25.0	14500	100.0	8.0	203.2
12G2L	3/4	19.1	1.15	29.2	3100	21.4	12400	85.5	9.5	241.3
16G2L	1	25.4	1.48	37.6	2400	16.5	9600	66.2	12.0	304.8
20G2L	1 1/4	31.8	1.84	46.7	1825	12.6	7300	50.3	16.5	419.1
24G2L	1 1/2	38.1	2.12	53.8	1300	9.0	5200	35.9	20.0	508.0
32G2L	2	50.8	2.62	66.5	1175	8.1	4700	32.4	25.0	635.0

EFG6KL / 6000 psi

4 层钢丝缠绕管

推荐用途 低温环境使用的高压、高脉冲及静压应用,适用于石油基液压油、聚乙二醇、植物油及水

内胶层 黑色耐油合成橡胶 (C类丁腈橡胶)

增强层 4层钢丝缠绕

外胶层 黑色耐油合成橡胶 (A类氯丁橡胶)

温度范围 -57°C~+100°C, 其它介质请参考温度限值表

适配接头 GS系列



订货型号	inch		mm	inch		mm	psi		Mpa	psi		Mpa	inch		mm
10EFG6KL	5/8		15.9	1.09		27.7	6000		34.5	24000		165.5	4.0		101.6
12EFG6KL	3/4		19.1	1.24		31.5	6000		34.5	20000		139.7	4.8		121.9
16EFG6KL	1		25.4	1.53		38.9	6000		34.5	20000		139.7	6.0		152.4

EFG5KL / 5000 psi

4-6 层钢丝缠绕管

推荐用途 低温环境使用的高压、高脉冲及静压应用,适用于石油基液压油、聚乙二醇、植物油及水

内胶层 黑色耐油合成橡胶 (C类丁腈橡胶)

增强层 4-6层钢丝缠绕 (-6至-16为4层, -20及以上为6层)

外胶层 黑色耐油合成橡胶 (A类氯丁橡胶)

温度范围 -57°C~+100°C, 其它介质请参考温度限值表

适配接头 GS、GSM系列, (-6至-20) 分体式GS系列, (-24) 一体式GSM系列



订货型号	inch		mm	inch		mm	psi		Mpa	psi		Mpa	inch		mm
6EFG5KL	3/8		9.5	0.80		20.3	5000		34.5	20000		139.7	2.5		63.5
8EFG5KL	1/2		12.7	0.95		24.1	5000		34.5	20000		139.7	3.5		88.9
12EFG5KL	3/4		19.1	1.24		31.5	5000		34.5	20000		139.7	4.8		121.9
16EFG5KL	1		25.4	1.53		38.9	5000		34.5	20000		139.7	6.0		152.4
20EFG5KL	1 1/4		31.8	1.97		50.0	5000		34.5	20000		139.7	8.2		208.3
24EFG5KL	1 1/2		38.1	2.26		57.4	5000		34.5	20000		139.7	10.0		254

EFG4KL / 4000 psi

4 层钢丝缠绕管

推荐用途 低温环境使用的高压、高脉冲及静压应用,适用于石油基液压油、聚乙二醇、植物油及水

内胶层 黑色耐油合成橡胶 (C类丁腈橡胶)

增强层 4层钢丝缠绕

外胶层 黑色耐油合成橡胶 (A类氯丁橡胶)

温度范围 -57°C~+100°C, 其它介质请参考温度限值表

适配接头 GS系列



订货型号	inch		mm	inch		mm	psi		Mpa	psi		Mpa	inch		mm
12EFG4KL	3/4		19.1	1.21		30.7	4000		27.6	16000		110.3	4.8		121.9
16EFG4KL	1		25.4	1.50		38.1	4000		27.6	16000		110.3	6.0		152.4
20EFG4KL	1 1/4		31.8	1.85		47.0	4000		27.6	16000		110.3	8.3		210.8

GlobalSpiral™ 缠绕管分体式接头

公制 24°锥外螺纹轻系列直接头

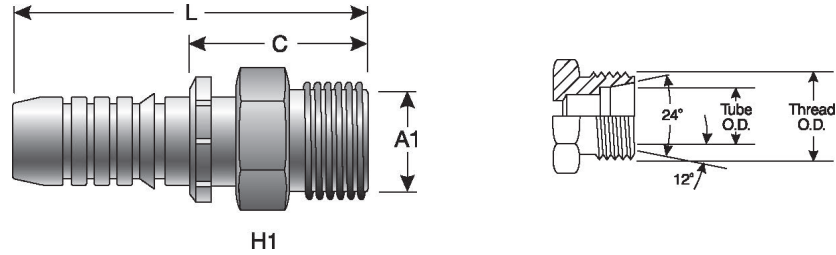

产品描述	编号	⊖			H1	H2	L		C		A1
		"	mm		mm	mm	mm	"	mm	"	mm
6GS-12MDL	7347-93445	3/8	9.5	M18X1.5	22.0	—	2.51	63.8	1.10	27.9	12.0
8GS-15MDL	7347-90625	1/2	12.7	M22X1.5	24.0	—	2.48	63.0	1.00	25.4	15.0
12GS-22MDL	7347-93565	3/4	19.1	M30X2.0	32.0	—	3.13	79.5	1.12	28.5	22.0
16GS-28MDL	7347-91495	1	25.4	M36X2.0	41.0	—	3.54	89.9	1.31	33.3	28.0
24GSP-42MDL	7347-9501	1 1/2	38.1	M52X2.0	55	—	4.72	119.9	1.83	46.5	42.0

公制 24°锥内螺纹带 O 型圈轻系列直接头

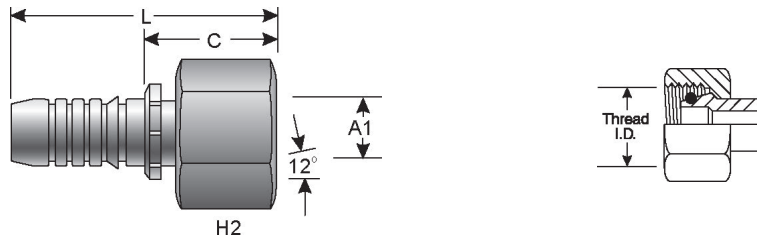

产品描述	编号	⊖			H1	H2	L		C		A1
		"	mm		mm	mm	mm	"	mm	"	mm
6GS-10FDLORX	7347-9544	3/8	9.5	M16X1.5	—	19.0	2.87	73.0	1.46	37.2	10.0
6GS-12FDLORX	7347-92815	3/8	9.5	M18X1.5	—	22.0	2.87	72.9	1.46	37.1	12.0
8GS-15FDLORX	7347-90595	1/2	12.7	M22X1.5	—	M27	2.87	72.9	1.40	35.6	15.0
8GS-18FDLORX	7347-0240	1/2	12.7	M26X1.5	—	32.0	2.87	73.0	1.40	35.5	18.0
10GS-18FDLORX	7347-92105	5/8	15.9	M26X1.5	—	32.0	3.61	91.7	1.63	41.4	18.0
12GS-22FDLORX	7347-92125	3/4	19.1	M30X2.0	—	36.0	3.82	97.0	1.81	46.0	22.0
12GS-28FDLORX	7347-92165	3/4	19.1	M36X2.0	—	41.0	3.90	99.1	1.89	48.1	28.0
16GS-28FDLORX	7347-90795	1	25.4	M36X2.0	—	41.0	4.13	104.9	1.91	48.5	28.0
20GS-35FDLORX	7347-94135	1 1/4	31.8	M45X2.0	—	50.0	5.21	132.3	2.41	61.2	35.0
24GSP-42FDLORX	7347-9495	1 1/2	38.1	M52X2.0	—	60.0	5.26	133.5	2.44	62.0	42.0
32GSP-42FDLORX	7347-9500	2	50.8	M52X2.0	—	60.0	5.70	145.0	2.09	53.1	42.0

GlobalSpiral™ 缠绕管分体式接头

公制 24°锥内螺纹带 O 型圈轻系列 45°弯接头

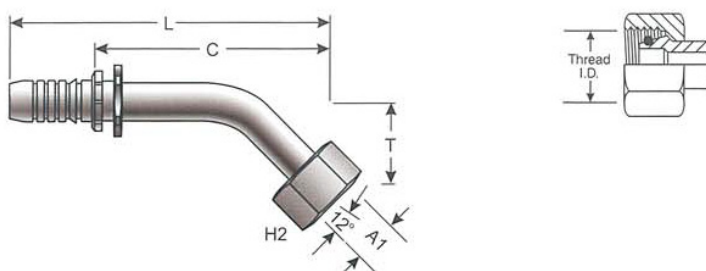

产品描述	编号	⊖		🌀	H1	H2	T		L		C		A1
		"	mm		mm	mm	"	mm	"	mm	"	mm	mm
6GS-10FDLORX45	7347-9546	3/8	9.5	M16X1.5	—	19.0	0.73	18.6	3.20	81.4	1.80	45.6	10.0
6GS-12FDLORX45	7347-9244	3/8	9.5	M18X1.5	—	22.0	0.74	18.9	3.41	86.7	2.00	50.8	12.0
8GS-15FDLORX45	7347-90605	1/2	12.7	M22X1.5	—	27.0	0.79	20.1	3.72	94.5	2.25	57.2	15.0
10GS-18FDLORX45	7347-9250	5/8	16.0	M26X1.5	—	32.0	0.98	24.8	4.80	121.9	2.82	71.6	35.0
12GS-22FDLORX45	7347-92525	3/4	19.1	M30X2.0	—	36.0	1.17	29.7	5.35	135.9	3.34	84.8	22.0
16GS-28FDLORX45	7347-91525	1	25.4	X36X2.0	—	41.0	1.21	30.7	6.12	155.5	3.90	99.1	28.0
20GS-35FDLORX45	7347-9417	1 1/4	31.8	M42X2.0	—	50.0	1.48	37.5	7.52	191.1	4.72	119.9	35.0
24GSP-2FDLORX45	7347-9509	1 1/2	38.1	M52X2.0	—	60.0	1.73	43.9	8.22	208.8	5.32	135.1	42.0

公制 24°锥内螺纹带 O 型圈轻系列 90°弯接头

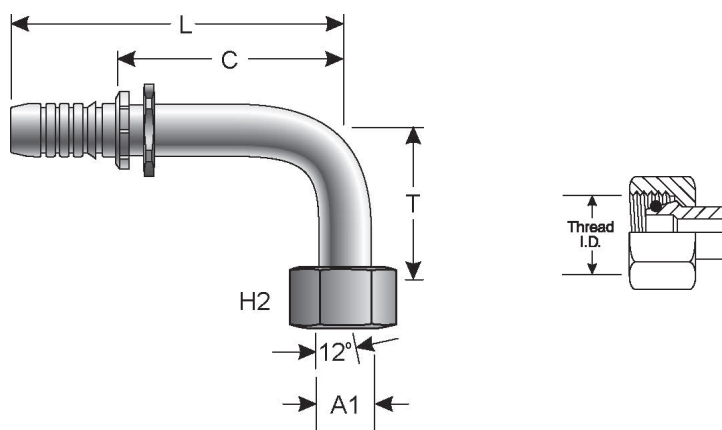

产品描述	编号	⊖		🌀	H1	H2	T		L		C		A1
		"	mm		mm	mm	"	mm	"	mm	"	mm	mm
6GS-10FDLORX90	7347-9545	3/8	9.5	M16X1.5	—	19.0	1.44	36.5	2.88	73.1	1.47	37.3	10.0
6GS-12FDLORX90	7347-92455	3/8	9.5	M19X1.5	—	22.0	1.45	36.8	3.07	78.0	1.66	42.2	12.0
8GS-15FDLORX90	7347-90615	1/2	12.7	M22X1.5	—	27.0	1.65	41.9	3.46	87.9	1.98	50.3	15.0
10GS-18FDLORX90	7347-92515	5/8	15.9	M26X1.5	—	32.0	2.03	51.6	4.47	113.5	2.49	63.3	18.0
12GS-22FDLORX90M	7347-92135	3/4	19.1	M30X2.0	—	36.0	2.44	62.0	4.86	123.4	2.86	72.6	22.0
16GS-28FDLORX90M	7347-90765	1	25.4	M36X2.0	—	41.0	2.76	70.1	5.82	147.8	2.71	68.8	28.0
20GS-35FDLORX90	7347-9414	1 1/4	31.8	M42X2.0	—	50.0	3.15	80.0	7.11	180.5	4.31	109.4	35.0
24GSP-42FDLORX90	7347-9496	1 1/2	38.1	M52X2.0	—	60.0	3.62	92.0	7.66	194.6	4.76	120.9	42.0

GlobalSpiral™ 缠绕管分体式接头

公制 24°锥外螺纹重系列直接头

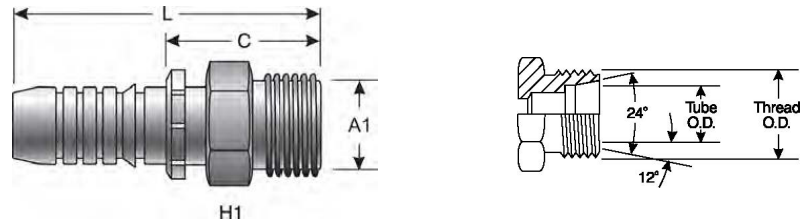

产品描述	编号	⊖			H1	H2	L		C		A1
		"	mm				"	mm	"	mm	
6GS-12MDH	7347-01785	3/8	9.5	M20X1.5	22.0	—	2.51	63.8	1.10	27.9	12.0
6GS-14MDH	7347-92675	3/8	9.5	M22X1.5	24.0	—	2.59	65.8	1.18	30.0	14.0
8GS-16MDH	7347-91325	1/2	12.7	M24X1.5	27.0	—	1.17	29.7	1.18	30.0	16.0
10GS-20MDH	7347-92695	5/8	15.9	M30X2.0	32.0	—	3.35	85.1	1.37	34.8	20.0
12GS-20MDH	7347-92255	3/4	19.1	M30X2.0	32.0	—	3.35	85.1	1.34	34.0	20.0
12GS-25MDH	7347-92265	3/4	19.1	M36X2.0	41.0	—	3.50	88.9	1.50	38.1	25.0
12GS-30MDH	7347-93765	3/4	19.1	M42X2.0	46.0	—	3.90	99.1	1.06	26.9	30.0
16GS-25MDH	7347-91505	1	25.4	M36X2.0	41.0	—	3.82	97.0	1.58	40.1	25.0
16GS-30MDH	7347-91515	1	25.4	M42X2.0	46.0	—	3.90	99.1	1.66	42.2	30.0
20GS-38MDH	7347-93295	1 1/4	31.8	M52X2.0	55.0	—	4.84	122.9	2.04	51.8	38.0

公制 24°锥内螺纹带 O 型圈重系列直接头

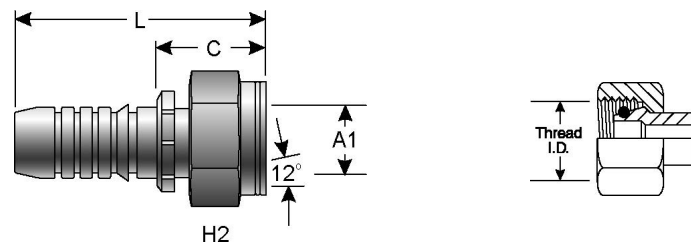

产品描述	编号	⊖			H1	H2	L		C		A1
		"	mm				"	mm	"	mm	
6GS-10FDHORX	7347-92635	3/8	9.5	M18X1.5	—	22.0	3.24	82.3	1.41	35.8	10.0
6GS-12FDHORX	7347-92645	3/8	9.5	M20X1.5	—	24.0	2.87	72.9	1.46	37.1	12.0
6GS-14FDHORX	7347-92085	3/8	9.5	M22X1.5	—	27.0	2.97	75.4	1.56	39.6	14.0
8GS-12FDHORX	7347-95195	1/2	12.7	M20X1.5	—	24.0	2.87	72.9	1.53	38.9	12.0
8GS-14FDHORX	7347-92095	1/2	12.7	M22X1.5	—	27.0	3.01	76.5	1.53	38.9	14.0
8GS-16FDHORX	7347-91335	1/2	12.7	M24X1.5	—	30.0	3.11	79.0	1.63	41.4	16.0
8GS-20FDHORX	7347-92715	1/2	12.7	M30X2.0	—	36.0	3.11	79.0	1.96	49.9	20.0
10GS-20FDHORX	7347-92115	5/8	15.9	M30X2.0	—	36.0	3.94	100.1	1.96	49.9	20.0
10GS-25FDHORX	7347-93425	5/8	15.9	M36X2.0	—	46.0	4.09	103.9	2.11	53.6	25.0
12GS-20FDHORX	7347-92145	3/4	19.1	M30X2.0	—	36.0	4.06	103.1	2.05	52.1	20.0
12GS-25FDHORX	7347-92155	3/4	19.1	M36X2.0	—	46.0	4.23	107.4	2.22	56.4	25.0
16GS-25FDHORX	7347-91535	1	25.4	M36X2.0	—	46.0	4.57	116.1	2.35	59.7	25.0
16GS-30FDHORX	7347-90805	1	25.4	M42X2.0	—	50.0	4.65	118.1	2.43	61.7	30.0
16GS-38FDHORX	7347-94225	1	25.4	M52X2.0	—	60.0	4.40	111.8	2.17	55.1	38.0
20GS-38FDHORX	7347-93305	1 1/4	31.8	M52X2.0	—	60.0	5.17	145.0	2.91	73.9	38.0
24GSP-38FDHORX	7347-9506	1 1/2	38.1	M52X2.0	—	60.0	5.91	150.1	3.00	76.2	38.0

GlobalSpiral™ 缠绕管分体式接头

公制 24°锥内螺纹带 O 型圈重系列 45°弯接头

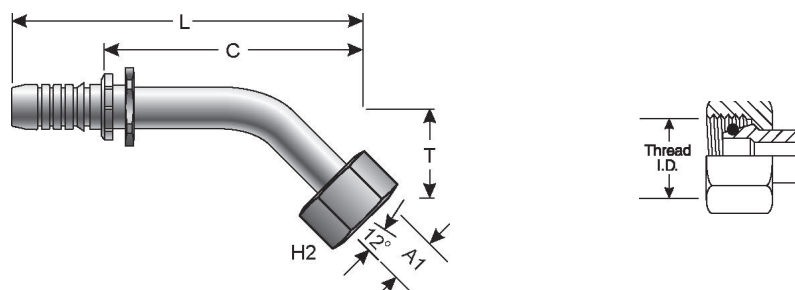

产品描述	编号	⊖		🌀	H1	H2	T		L		C		A1
		"	mm		mm	"	mm	"	mm	"	mm	"	mm
6GS-12FDHORX45	7347-92425	3/8	9.5	M20X1.5	—	24.0	2.87	72.9	2.97	75.4	1.41	35.8	12.0
6GS-14FDHORX45	7347-92465	3/8	9.5	M22X1.5	—	27.0	2.97	75.4	3.31	84.1	1.46	37.1	14.0
8GS-16FDHORX45M	7347-91345	1/2	12.7	M24X1.5	—	30.0	0.85	21.6	3.70	94.0	2.23	56.6	16.0
10GS-20FDHORX45	7347-92325	5/8	15.9	M30X2.0	—	36.0	0.98	24.9	4.79	121.7	2.81	71.4	20.0
12GS-20FDHORX45	7347-93285	3/4	19.1	M30X2.0	—	36.0	1.17	29.7	6.33	160.8	4.33	110.0	20.0
12GS-25FDHORX45M	7347-92175	3/4	19.1	M36X2.0	—	46.0	1.23	31.2	5.31	134.9	3.40	86.4	25.0
16GS-25FDHORX45M	7347-91545	1	25.4	M36X2.0	—	46.0	1.38	35.1	3.90	99.1	1.66	42.2	25.0
16GS-30FDHORX45	7347-91565	1	25.4	M42X2.0	—	50.0	1.38	35.1	6.29	159.8	4.07	103.4	30.0
20GS-38FDHORX45M	7347-93415	1 1/4	31.8	M52X2.0	—	60.0	1.67	42.4	7.72	196.1	4.92	125.0	38.0

公制 24°锥内螺纹带 O 型圈重系列 90°弯接头

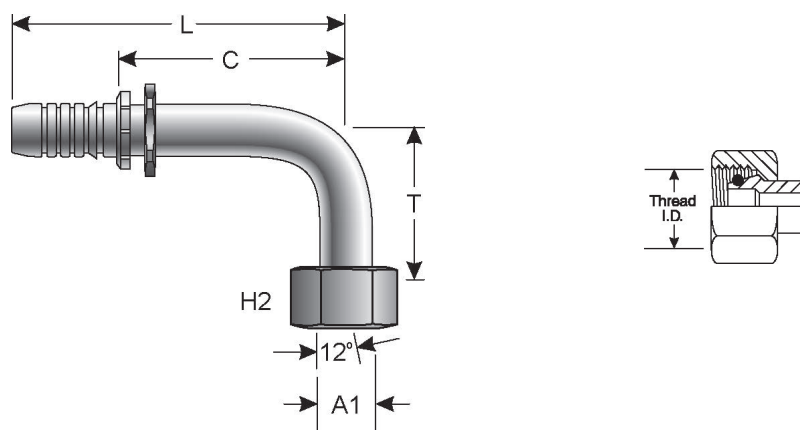

产品描述	编号	⊖		🌀	H1	H2	T		L		C		A1
		"	mm		mm	"	mm	"	mm	"	mm	"	mm
6GS-12FDHORX90	7347-92435	3/8	9.5	M20X1.5	—	24.0	1.45	36.8	3.07	78.0	1.46	37.1	12.0
6GS-14FDHORX90	7347-92475	3/8	9.5	M22X1.5	—	27.0	1.57	39.9	3.07	78.0	1.66	42.2	14.0
8GS-16FDHORX90M	7347-91485	1/2	12.7	M24X1.5	—	30.0	1.73	43.9	3.39	86.1	1.91	48.5	16.0
10GS-20FDHORX90M	7347-92335	5/8	15.9	M30X2.0	—	36.0	2.01	51.1	4.43	112.5	2.45	62.2	20.0
12GS-20FDHORX90M	7347-92185	3/4	19.1	M30X2.0	—	36.0	2.44	62.0	4.86	123.4	2.85	72.4	20.0
12GS-25FDHORX90M	7347-92195	3/4	19.1	M36X2.0	—	46.0	2.52	64.0	4.86	123.4	2.85	72.4	25.0
16GS-25FDHORX90	7347-91555	1	25.4	M36X2.0	—	46.0	2.99	76.0	5.94	150.9	3.72	94.5	25.0
16GS-30FDHORX90M	7347-90775	1	25.4	M42X2.0	—	50.0	2.99	76.0	5.81	147.6	3.59	91.2	30.0
20GS-38FDHORX90M	7347-93315	1 1/4	31.8	M52X2.0	—	60.0	3.43	87.1	7.11	180.6	4.31	109.5	30.0
24GSP-38FDHORX90	7347-9508	1 1/2	38.1	M52X2.0	—	60.0	3.62	91.9	7.67	194.6	4.76	120.9	38.0

GlobalSpiral™ 缠绕管分体式接头

NPTF 锥管外螺纹直接头

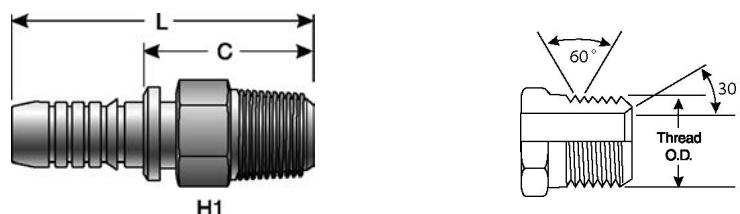

产品描述	编号	⊖		🌀	H1	H2	L		C	
		"	mm		"	"	"	mm	"	mm
6GS-6MP	7347-20145	3/8	9.5	3/8-18	11/16	—	2.72	69.1	1.31	33.3
6GS-8MP	7347-20155	3/8	9.5	1/2-14	7/8	—	2.87	72.9	1.46	37.1
8GS-8MP	7347-20245	1/2	12.7	1/2-14	7/8	—	2.91	73.9	1.43	36.3
8GS-12MP	7347-20265	1/2	12.7	3/4-14	1 1/16	—	3.03	77.0	1.56	39.6
10GS-8MP	7347-20335	5/8	15.9	1/2-14	15/16	—	3.35	85.1	1.34	34.0
10GS-12MP	7347-20355	5/8	15.9	3/4-14	1 1/8	—	3.58	90.9	1.60	40.6
12GS-8MP	7347-20425	3/4	19.1	1/2-14	1 1/16	—	3.54	89.9	1.54	39.1
12GS-12MP	7347-20445	3/4	19.1	3/4-14	1 1/16	—	3.54	89.9	1.54	39.1
12GS-16MP	7347-20465	3/4	19.1	1-11 1/2	1 3/8	—	3.82	97.0	1.81	46.0
16GS-12MP	7347-20535	1	25.4	3/4-14	1 3/8	—	3.98	101.1	1.74	44.2
16GS-16MP	7347-20555	1	25.4	1-11 1/2	1 3/8	—	4.17	105.9	1.94	49.3
16GS-20MP	7347-20565	1	25.4	1 1/4-11 1/2	1 3/4	—	4.29	109.0	2.06	52.3
20GS-20MP	7347-20645	1 1/4	31.8	1 1/4-11 1/2	1 3/4	—	5.00	127.0	2.20	55.9
24GSP-24MP	7347-20725	1 1/2	38.1	1 1/2-11 1/2	2	—	5.24	133.1	2.34	59.4
32GSP-32MP	7347-20795	2	50.8	2-11 1/2	2.50	—	6.05	153.7	2.43	61.7

SAE 直管外螺纹带 O 型圈直接头

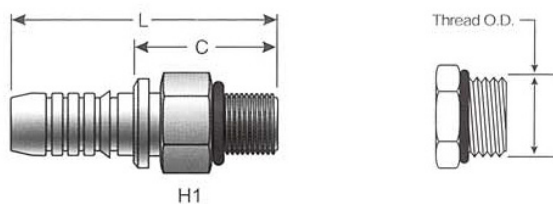

产品描述	编号	⊖		🌀	H1	H2	L		C	
		"	mm		mm	mm	"	mm	"	mm
6GS-6MB	7347-21145	3/8	9.5	9/16-18	11/16	—	2.56	65.0	1.15	29.2
8GS-8MB	7347-21245	1/2	12.7	3/4-16	7/8	—	2.76	70.1	1.26	32.0
8GS-10MB	7347-21255	1/2	12.7	7/8-14	1	—	2.83	71.9	1.34	34.0
10GS-10MB	7347-21345	5/8	15.9	7/8-14	1	—	3.46	87.9	1.48	37.6
10GS-12MB	7347-21355	5/8	15.9	1 1/16-12	1 1/4	—	3.46	87.9	1.48	37.6
12GS-12MB	7347-21445	3/4	19.1	1 1/16-12	1 1/4	—	3.66	93.0	1.65	41.9
12GS-16MB	7347-21465	3/4	19.1	1 5/16-12	1 1/2	—	3.54	89.9	1.54	39.1
16GS-12MB	7347-21535	1	25.4	1 1/16-12	1 3/8	—	3.98	101.1	1.74	44.2
16GS-16MB	7347-21555	1	25.4	1 5/16-12	1 1/2	—	3.86	98.1	1.62	41.2
16GS-20MB	7347-21565	1	25.4	1 5/8-12	1 7/8	—	4.53	115.1	1.62	41.2
20GS-20MB	7347-21645	1 1/4	31.8	1 5/8-12	1 7/8	—	4.53	115.1	1.73	43.9

GlobalSpiral™ 缠绕管分体式接头

JIC 37°外螺纹直接头

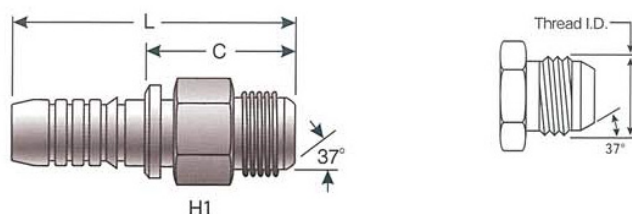

产品描述	编号	⊖			H1	H2	L		C	
		"	mm				"	mm	"	mm
6GS-6MJ	7347-22145	3/8	9.5	9/16-18	11/16	—	2.60	66.0	1.19	30.2
6GS-8MJ	7347-22155	3/8	9.5	3/4-16	13/16	—	2.76	70.1	1.35	34.3
6GS-10MJ	7347-22165	3/8	9.5	7/8-14	15/16	—	3.03	77.0	1.62	41.2
8GS-8MJ	7347-22245	1/2	12.7	3/4-16	13/16	—	2.83	71.9	1.36	34.5
8GS-10MJ	7347-22255	1/2	12.7	7/8-14	7/8	—	2.95	74.9	1.48	37.6
10GS-10MJ	7347-22345	5/8	15.9	7/8-14	15/16	—	3.62	92.0	1.64	41.7
10GS-12MJ	7347-22355	5/8	15.9	1 1/16-12	1 1/16	—	3.70	94.0	1.72	43.7
12GS-12MJ	7347-22445	3/4	19.1	1 1/16-12	1 1/8	—	3.66	93.0	1.65	41.9
12GS-14MJ	7347-22455	3/4	19.1	1 3/16-12	1 1/4	—	3.70	94.0	1.69	42.9
12GS-16MJ	7347-22465	3/4	19.1	1 5/16-12	1 5/16	—	3.78	96.0	1.77	45.0
16GS-16MJ	7347-22555	1	25.4	1 5/16-12	1 3/8	—	4.09	103.9	1.86	47.2
16GS-20MJ	7347-22585	1	25.4	1 5/8-12	1 3/4	—	4.27	108.5	2.04	51.8
20GS-20MJ	7347-22645	1 1/4	31.8	1 5/8-12	1 3/4	—	4.92	125.0	2.12	53.9
24GSP-20MJ	7347-81455	1 1/2	38.1	1 5/8-12	1.97	—	5.00	127.0	2.10	53.3
24GSP-24MJ	7347-81465	1 1/2	38.1	1 7/8-12	1.97	—	5.12	130.1	2.22	56.4
32GSP-32MJ	7347-81535	2	50.8	2 1/2-12	2.56	—	6.34	161.0	2.72	69.1

JIC 37°内螺纹直接头

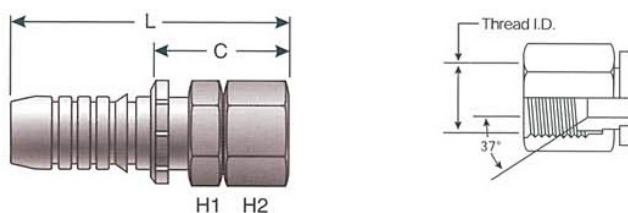

产品描述	编号	⊖			H1	H2	L		C	
		"	mm				"	mm	"	mm
6GS-6FJX	7347-24145	3/8	9.5	9/16-18	3/4	3/4	2.72	69.1	1.31	33.3
6GS-8FJX	7347-24155	3/8	9.5	3/4-16	3/4	7/8	2.80	71.1	1.39	35.3
8GS-8FJX	7347-24245	1/2	12.7	3/4-16	7/8	7/8	2.83	71.9	1.36	34.5
8GS-10FJX	7347-24255	1/2	12.7	7/8-14	7/8	1 1/16	2.99	76.0	1.51	38.4
8GS-12FJX	7347-24265	1/2	12.7	1 1/16-12	7/8	1 1/4	3.03	77.0	1.56	39.6
10GS-10FJX	7347-82175	5/8	15.9	7/8-14	1	1 1/16	3.68	93.5	1.70	43.2
10GS-12FJX	7347-24355	5/8	15.9	1 1/16-12	1	1 1/4	3.74	95.0	1.76	44.7
12GS-10FJX	7347-24435	3/4	19.1	7/8-14	1 1/16	1 1/8	3.87	98.3	1.87	47.5
12GS-12FJX	7347-24445	3/4	19.1	1 1/16-12	1	1 1/4	3.87	98.3	1.85	47.2
12GS-14FJX	7347-24455	3/4	19.1	1 3/16-12	1 1/8	1 3/8	4.06	103.1	2.06	52.3
12GS-16FJX	7347-24465	3/4	19.1	1 5/16-12	1 1/4	1 1/2	4.02	102.1	2.01	51.1
16GS-12FJX	7347-24535	1	25.4	1 1/16-12	1 3/8	1 3/8	4.25	108.0	2.00	50.8
16GS-14FJX	7347-24545	1	25.4	1 3/16-12	1 3/8	1 1/2	4.25	108.0	2.01	51.1
16GS-16FJX	7347-24555	1	25.4	1 5/16-12	1 1/2	1 1/2	4.30	109.2	2.07	52.6

GlobalSpiral™ 缠绕管分体式接头

JIC 37°内螺纹直接头

产品描述	编号	⊖			H1	H2	L		C	
		"	mm		"	"	"	mm	"	mm
16GS-20FJX	7347-24565	1	25.4	1 5/8-12	1 1/2	2	4.53	115.1	2.31	58.7
20GS-16FJX	7347-24635	1 1/4	31.8	1 5/16-12	1 3/4	1 5/8	5.08	129.0	2.28	57.9
20GS-20FJX	7347-24645	1 1/4	31.8	1 5/8-12	1 7/8	2	5.29	134.4	2.56	65.0
20GS-24FJX	7347-24655	1 1/4	31.8	1 7/8-12	1 7/8	2 3/8	5.39	136.9	2.59	65.8
20GSP-24FJX	7347-82455	1 1/2	38.1	1 7/8-12	1.97	2.36	5.64	143.3	2.74	69.6
24GSP-32FJX	7347-82465	1 1/2	38.1	2 1/2-12	2.56	2.98	6.88	174.8	3.17	80.5
32GSP-32FJX	7347-82525	2	50.8	2 1/2-12	2.56	2.95	6.80	172.7	3.17	80.5

JIC 37°内螺纹 30°弯接头

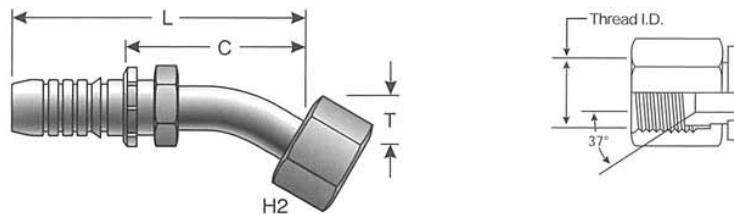

产品描述	编号	⊖			H1	H2	T		L		C	
		"	mm		"	"	"	mm	"	mm	"	mm
16GS-16FJX30M	7347-73055	1	25.4	1 5/16-12	—	1 1/2	1.06	26.9	6.02	152.9	3.80	96.5

JIC 37°内螺纹 45°弯接头

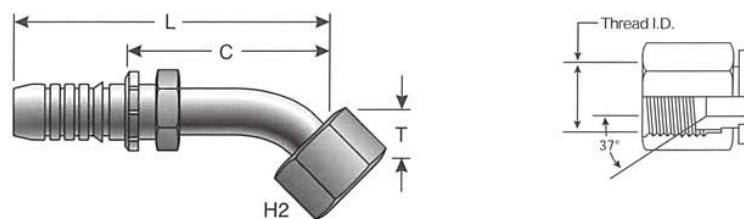

产品描述	编号	⊖			H1	H2	T		L		C	
		"	mm		"	"	"	mm	"	mm	"	mm
6GS-6FJX45S	7347-25145	3/8	9.5	9/16-18	3/4	3/4	.43	10.9	3.23	82.0	1.82	46.2
6GS-8FJX45S	7347-25155	3/8	9.5	3/4-16	3/4	7/8	.59	15.0	3.66	93.0	2.25	57.2
8GS-8FJX45S	7347-25245	1/2	12.7	3/4-16	7/8	7/8	.59	15.0	3.70	94.0	2.22	56.4
8GS-10FJX45S	7347-25255	1/2	12.7	7/8-14	7/8	1 1/16	.63	16.0	3.58	90.9	2.11	53.6
10GS-10FJXMM45-018	7347-83275	5/8	15.9	7/8-14	—	1 1/16	.71	18.0	4.45	113.0	2.48	63.0
10GS-12FJX45S	7347-25355	5/8	15.9	1 1/16-12	1	1 1/4	.83	21.1	4.80	121.9	2.82	71.6
12GS-12FJX45S	7347-25445	3/4	19.1	1 1/16-12	—	1 1/4	.83	21.1	5.12	130.1	3.11	79.0
12GS-16FJX45S	7347-25465	3/4	19.1	1 5/16-12	—	1 1/2	.94	23.9	5.39	136.9	3.39	86.1
16GS-16FJX45M	7347-26555	1	25.4	1 5/16-12	—	1 1/2	1.50	38.1	6.30	160.0	4.07	103.4
16GS-16FJX45S	7347-25555	1	25.4	1 5/16-12	1 1/2	1 1/2	.94	23.9	5.98	151.9	3.77	95.8
16GS-20FJX45S	7347-25565	1	25.4	1 5/8-12	—	2	.98	24.9	6.46	164.1	4.23	107.4
20GS-20FJX45-038	7347-76175	1 1/4	31.8	1 5/8-12	—	2	1.50	38.1	7.09	180.1	4.29	109.0
24GSP-24FJX45-050	7347-83735	1 1/2	38.1	1 7/8-12	2.16	2.36	1.97	50.0	9.17	232.9	6.28	159.5

GlobalSpiral™ 缠绕管分体式接头

JIC 37°内螺纹 90°弯接头

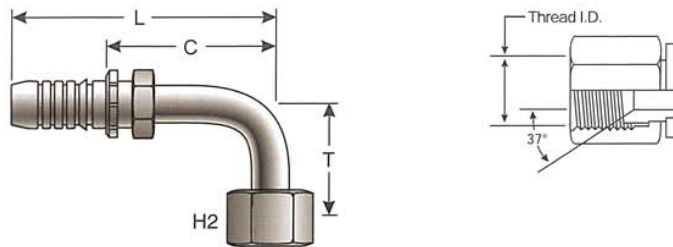

产品描述	编号	⊖			H1	H2	T		L		C	
		"	mm				"	mm	"	mm	"	mm
6GS-6FJX90L	7347-29145	3/8	9.5	9/16-18	3/4	3/4	2.13	54.1	3.39	86.1	1.98	50.3
6GS-6FJX90S	7347-27145	3/8	9.5	9/16-18	3/4	3/4	.91	23.1	3.11	79.0	1.70	43.2
6GS-6FJXMM90M	7347-84045	3/8	9.5	9/16-18	7/8	3/4	1.50	38.1	3.11	79.0	1.70	43.2
6GS-8FJX90-083	7347-76785	3/8	9.5	3/4-16	3/4	7/8	3.27	83.1	3.58	90.9	2.17	55.1
6GS-8FJX90M	7347-28155	3/8	9.5	3/4-16	3/4	7/8	1.61	40.9	3.58	90.9	2.17	55.1
8GS-8FJX90L	7347-29245	1/2	12.7	3/4-16	7/8	7/8	2.52	64.0	3.62	92.0	2.15	54.6
8GS-8FJX90M	7347-28245	1/2	12.7	3/4-16	7/8	7/8	1.61	40.9	3.62	92.0	2.15	54.6
8GS-8FJX90S	7347-27245	1/2	12.7	3/4-16	7/8	7/8	1.14	29.0	3.39	86.1	1.91	48.5
8GS-8FJX90XL	7347-73065	1/2	12.7	3/4-16	7/8	7/8	4.06	103.1	3.62	92.0	2.15	54.6
8GS-10FJX90L	7347-29255	1/2	12.7	7/8-14	7/8	1 1/16	3.27	83.1	3.74	95.0	2.26	57.4
8GS-10FJX90M	7347-28165	1/2	12.7	7/8-14	7/8	1 1/16	1.85	47.0	3.50	88.9	2.01	51.1
8GS-10FJX90S	7347-27255	1/2	12.7	7/8-14	7/8	1 1/16	1.26	32.0	3.62	92.0	2.15	54.6
8GS-12FJX90S	7347-27265	1/2	12.7	1 1/16-12	7/8	1 1/4	1.89	48.0	4.37	111.0	2.89	73.4
10GS-10FJXMM90-036	7347-84275	5/8	15.9	7/8-14	—	1 1/16	1.42	36.1	4.37	111.0	1.70	43.2
10GS-10FJXMM90M	7347-84285	5/8	15.9	7/8-14	1	1 1/16	1.85	47.0	4.21	106.9	2.23	56.6
10GS-12FJX90M	7347-28355	5/8	15.9	1 1/16-12	1	1 1/4	2.28	57.9	4.76	120.9	2.78	70.6
12GS-12FJX90L	7347-29445	3/4	19.1	1 1/16-12	—	1 1/4	3.78	96.0	4.45	113.0	2.44	62.0
12GS-12FJX90M	7347-28445	3/4	19.1	1 1/16-12	—	1 1/4	2.28	57.9	4.45	113.0	2.44	62.0
12GS-12FJX90S	7347-27445	3/4	19.1	1 1/16-12	—	1 1/4	1.89	48.0	4.45	113.0	2.44	62.0
12GS-14FJX90-60	7347-28455	3/4	19.1	1 3/16-12	—	1 3/8	2.36	59.9	5.55	141.0	3.54	89.9
12GS-16FJX90L	7347-29465	3/4	19.1	1 5/16-12	—	1 1/2	4.49	114.1	5.32	135.1	3.31	84.1
12GS-16FJX90M	7347-28465	3/4	19.1	1 5/16-12	—	1 1/2	2.80	71.1	5.31	134.9	3.31	84.1
12GS-16FJX90S	7347-27465	3/4	19.1	1 5/16-12	—	1 1/2	2.20	55.9	5.31	134.9	3.31	84.1
16GS-16FJX90L	7347-29555	1	25.4	1 5/16-12	1 1/2	1 1/2	4.33	110.0	5.67	144.0	3.45	87.6
16GS-16FJX90M	7347-28555	1	25.4	1 5/16-12	1 1/2	1 1/2	2.80	71.1	5.67	144.0	3.45	87.6
16GS-16FJX90S	7347-27555	1	25.4	1 5/16-12	—	1 1/2	2.20	55.9	5.67	144.0	3.45	87.6
16GS-20FJX90L	7347-29565	1	25.4	1-5/8-12	1 1/2	2	5.08	129.0	6.06	153.9	3.84	97.5
20GS-20FJX90L	7347-29645	1 1/4	31.8	1 5/8-12	—	2	5.08	129.0	6.85	174.0	4.05	102.9
20GS-20FJX90M	7347-28645	1 1/4	31.8	1 5/8-12	—	2	3.07	78.0	6.85	174.0	4.05	102.9
20GS-20FJX90S	7347-27645	1 1/4	31.8	1 5/8-12	—	2	2.52	64.0	6.85	174.0	4.05	102.9
20GS-24FJX90M	7347-28655	1 1/4	31.8	1 7/8-12	—	2 3/8	3.39	86.1	7.32	185.9	4.52	114.8
24GSP-24FJX90-089	7347-84745	1 1/2	38.1	1 7/8-12	2.16	2.36	3.50	88.9	8.35	212.1	5.45	138.4
24GSP-24FJX90-118	7347-84755	1 1/2	38.1	1 7/8-12	2.16	2.36	4.65	118.1	7.46	189.5	4.65	115.8
32GSP-32FJX90M	7347-84785	2	50.8	2 1/2-12	2.56	2.95	5.51	140.0	10.71	272.0	7.07	179.6

GlobalSpiral™ 缠绕管分体式接头

ORFS 平面密封内螺纹直接头

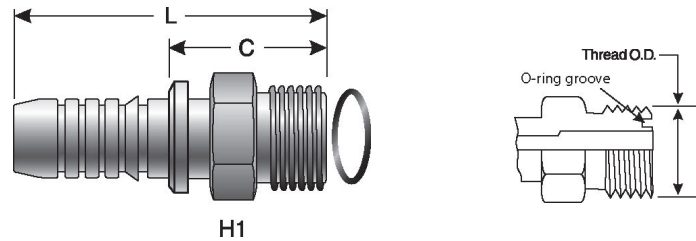

产品描述	编号	⊖		🌀	H1	H2	L		C	
		"	mm		"	"	"	mm	"	mm
6GS-6MFFOR	7347-23865	3/8	9.5	11/16-16	19.0	-	2.52	64.0	1.11	28.2
8GS-8MFFOR	7347-23825	1/2	12.7	13/16-16	22.0	-	2.68	68.1	1.20	79.0
8GS-10MFFOR	7347-23895	1/2	12.7	1-14	27.0	-	2.91	73.9	1.44	79.0
10GS-10MFFOR	7347-23875	5/8	15.9	1-14	27.0	-	3.42	86.9	1.44	90.9
10GS-12MFFOR	7347-23885	5/8	15.9	13/16-12	32.0	-	3.50	88.9	1.52	90.9
12GS-12MFFOR	7347-23835	3/4	19.1	13/16-12	32.0	-	3.50	88.9	1.50	92.0
12GS-16MFFOR	7347-23845	3/4	19.1	17/16-12	41.0	-	3.74	95.0	1.73	88.9
16GS-16MFFOR	7347-23815	1	25.4	17/16-12	41.0	-	4.02	102.1	1.78	92.0
16GS-20MFFOR	7347-23825	1	25.4	111/16-12	50.0	-	4.70	119.4	1.78	86.1
20GS-20MFFOR	7347-23855	1 1/4	31.8	111/16-12	50.0	-	4.72	119.9	1.93	92.0
24GS-24MFFOR	7347-23805	1 1/2	38.1	2-12	55.0	-	5.12	130.1	2.22	95.0

ORFS 平面密封内螺纹直接头

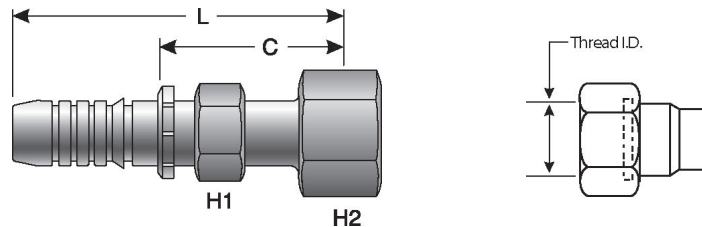

产品描述	编号	⊖		🌀	H1	H2	L		C	
		"	mm		"	"	"	mm	"	mm
6GS-6FFORX	7347-30145	3/8	9.5	9/16-18	22.0	22.0	3.39	86.1	1.98	50.3
6GS-8FFORX	7347-30155	3/8	9.5	9/16-18	22.0	24.0	3.11	79.0	1.70	43.2
8GS-8FFORX	7347-30245	1/2	12.7	9/16-18	27.0	24.0	3.11	79.0	1.70	43.2
8GS-10FFORX	7347-30255	1/2	12.7	3/4-16	27.0	30.0	3.58	90.9	2.17	55.1
8GS-12FFORX	7347-30265	1/2	12.7	3/4-16	27.0	36.0	3.58	90.9	2.17	55.1
10GS-10FFORX	7347-30345	5/8	15.9	3/4-16	30.0	30.0	3.62	92.0	2.15	54.6
10GS-12FFORX	7347-28245	5/8	15.9	3/4-16	30.0	36.0	3.62	92.0	2.15	54.6
12GS-10FFORX	7347-27245	3/4	19.1	3/4-16	32.0	30.0	3.39	86.1	1.91	48.5
12GS-12FFORX	7347-73065	3/4	19.1	3/4-16	32.0	36.0	3.62	92.0	2.15	54.6
12GS-16FFORX	7347-29255	3/4	19.1	7/8-14	32.0	41.0	3.74	95.0	2.26	57.4
12GS-20FFORX	7347-28165	3/4	19.1	7/8-14	32.0	50.0	3.50	88.9	2.01	51.1
16GS-12FFORX	7347-27255	1	25.4	7/8-14	36.0	36.0	3.62	92.0	2.15	54.6
16GS-16FFORX	7347-27265	1	25.4	1 1/16-12	41.0	41.0	4.37	111.0	2.89	73.4
16GS-20FFORX	7347-84275	1	25.4	111/16-12	41.0	50.0	4.37	111.0	1.70	43.2
20GS-20FFORX	7347-84285	1 1/4	31.8	111/16-12	50.0	50.0	4.21	106.9	2.23	56.6
20GS-24FFORX	7347-28355	1 1/4	31.8	2-12	50.0	60.0	4.76	120.9	2.78	70.6
24GS-24FFORX	7347-29445	1 1/2	38.1	2-12	55.0	60.0	4.45	113.0	2.44	62.0

GlobalSpiral™ 缠绕管分体式接头

ORFS 平面密封内螺纹 22¹/₂°弯接头

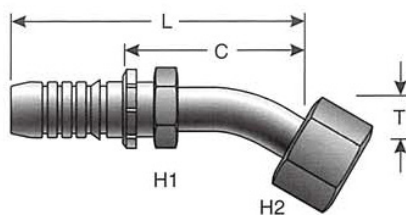

产品描述	编号	⊖			H1	H2	T		L		C	
		"	mm		mm	mm	"	mm	"	mm	"	mm
16GS-16FFORX22-011	7347-708615	1	25.4	1 7/16-12	41.0	41.0	.43	10.9	5.87	149.1	3.68	93.5

ORFS 平面密封内螺纹 45°弯接头

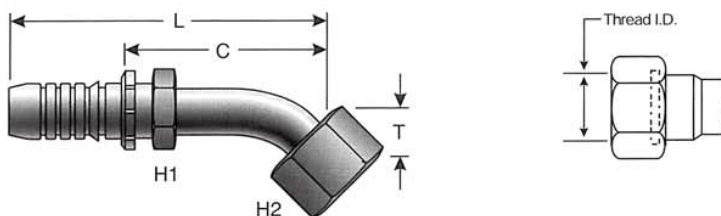

产品描述	编号	⊖			H1	H2	T		L		C	
		"	mm		mm	mm	"	mm	"	mm	"	mm
6GS-6FFORX45S	7347-31145	3/8	9.5	11/16-16	22.0	22.0	.43	10.9	3.23	82.0	1.82	46.2
6GS-8FFORX45S	7347-31155	3/8	9.5	13/16-16	22.0	24.0	.59	15.0	3.66	93.0	2.25	57.2
8GS-8FFORX45S	7347-31245	1/2	12.7	13/16-16	27.0	24.0	.59	15.0	3.70	94.0	2.22	56.4
8GS-10FFORX45S	7347-31255	1/2	12.7	1-14	27.0	30.0	.63	16.0	3.90	99.1	2.42	61.5
8GS-12FFORX45S	7347-31265	1/2	12.7	1 3/16-12	30.0	36.0	.83	21.1	4.53	115.1	3.05	77.5
10GS-10FFORX45S	7347-31345	5/8	15.9	1-14	30.0	30.0	.63	16.0	4.37	111.0	2.39	60.7
10GS-12FFORX45S	7347-3135	5/8	16.0	1 3/16-12	30.0	36.0	.83	21.0	4.80	122.0	2.82	71.7
12GS-12FFORX45S	7347-31445	3/4	19.1	1 3/16-12	32.0	36.0	.83	21.1	4.92	125.0	2.91	73.9
12GS-16FFORX45S	7347-31465	3/4	19.1	1 7/16-12	32.0	41.0	.94	23.9	5.39	136.9	3.39	86.1
16GS-16FFORX45S	7347-31555	1	25.4	1 7/16-12	41.0	41.0	.94	23.9	5.67	144.0	3.46	87.9
16GS-20FFORX45S	7347-31565	1	25.4	1 11/16-12	41.0	50.0	.98	24.9	6.46	164.1	4.24	107.7
20GS-20FFORX45-032	7347-76045	1 1/4	31.8	1 11/16-12	50.0	50.0	1.26	32.0	7.09	180.1	4.29	109.0
20GSP-24FFORX45-036	7347-31725	1 1/2	38.1	2-12	55.0	60.0	2.70	68.6	7.61	193.3	4.81	122.2

GlobalSpiral™ 缠绕管分体式接头

ORFS 平面密封内螺纹 90°弯接头

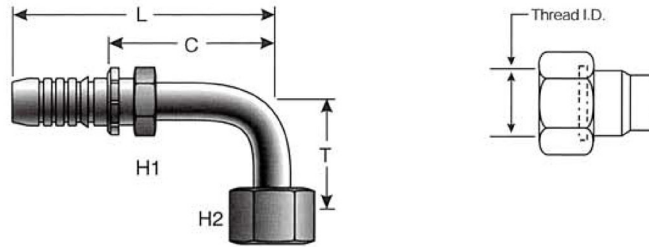

产品描述	编号	⊖		🌀	H1	H2	T		L		C	
		"	mm				"	mm	"	mm	"	mm
6GS-6FFORX90L	7347-34145	3/8	9.5	11/16-16	22.0	22.0	2.13	54.1	3.35	85.1	1.94	49.3
6GS-6FFORX90S	7347-32145	3/8	9.5	11/16-16	22.0	22.0	.91	23.1	3.07	78.0	1.66	42.2
6GS-8FFORX90M	7347-33155	3/8	9.5	13/16-16	22.0	24.0	1.61	40.9	3.35	85.1	1.94	49.3
8GS-8FFORX90-083	7347-73855	1/2	12.7	13/16-16	27.0	24.0	3.27	83.1	3.39	86.1	1.91	48.5
8GS-8FFORX90M	7347-33245	1/2	12.7	13/16-16	27.0	24.0	1.61	40.9	3.39	86.1	1.91	48.5
8GS-8FFORX90S	7347-32245	1/2	12.7	13/16-16	27.0	24.0	1.14	29.0	3.39	86.1	1.91	48.5
8GS-10FFORX90L	7347-34245	1/2	12.7	1-14	27.0	30.0	2.76	70.1	3.98	101.1	2.50	63.5
8GS-10FFORX90M	7347-33255	1/2	12.7	1-14	27.0	30.0	1.85	47.0	3.98	101.1	2.50	63.5
8GS-10FFORX90S	7347-32255	1/2	12.7	1-14	27.0	30.0	1.26	32.0	3.98	101.1	2.50	63.5
8GS-12FFORX90S	7347-32265	1/2	12.7	1 3/16-12	27.0	36.0	1.89	48.0	4.21	106.9	2.74	69.6
10GS-10FFORX90L	7347-34345	5/8	15.9	1-14	30.0	30.0	2.76	70.1	4.45	113.0	2.44	62.0
10GS-10FFORX90M	7347-33345	5/8	15.9	1-14	30.0	30.0	1.85	47.0	4.21	106.9	2.20	55.9
10GS-10FFORX90S	7347-32345	5/8	15.9	1-14	30.0	30.0	1.26	32.0	4.20	106.7	2.22	56.4
10GS-12FFORXMM90S-048	7347-32355	5/8	15.9	1 3/16-12	30.0	36.0	1.26	32.0	4.21	106.9	2.74	69.6
12GS-10FFORX90S	7347-32435	3/4	19.1	1-14	32.0	30.0	1.26	32.0	4.37	111.0	2.36	59.9
12GS-12FFORX90L	7347-34445	3/4	19.1	1 3/16-12	32.0	36.0	3.78	96.0	5.04	128.0	3.03	77.0
12GS-12FFORX90M	7347-33445	3/4	19.1	1 3/16-12	32.0	36.0	2.28	57.9	5.04	128.0	3.03	77.0
12GS-12FFORX90S	7347-32445	3/4	19.1	1 3/16-12	32.0	36.0	1.89	48.0	5.04	128.0	3.03	77.0
12GS-16FFORX90L	7347-34465	3/4	19.1	1 7/16-12	32.0	41.0	4.49	114.1	5.39	136.9	3.39	86.1
12GS-16FFORX90M	7347-33465	3/4	19.1	1 7/16-12	32.0	41.0	2.80	71.1	5.39	136.9	3.39	86.1
12GS-16FFORX90S	7347-32465	3/4	19.1	1 7/16-12	32.0	41.0	2.20	55.9	5.39	136.9	3.39	86.1
16GS-16FFORX90L	7347-34555	1	25.4	1 7/16-12	41.0	41.0	4.49	114.1	5.67	144.0	3.45	87.6
16GS-16FFORX90M	7347-33555	1	25.4	1 7/16-12	41.0	41.0	2.80	71.1	5.67	144.0	3.45	87.6
16GS-16FFORX90S	7347-32555	1	25.4	1 7/16-12	41.0	41.0	2.20	55.9	5.67	144.0	3.45	87.6
16GS-20FFORX90L	7347-34565	1	25.4	1 11/16-12	41.0	50.0	5.08	129.0	6.05	153.7	3.83	97.3
16GS-20FFORX90M	7347-33565	1	25.4	1 11/16-12	41.0	50.0	3.07	78.0	6.05	153.7	3.83	97.3
16GS-20FFORX90S	7347-32565	1	25.4	1 11/16-12	41.0	50.0	2.52	64.0	6.06	153.9	3.84	97.5
20GS-20FFORX90L	7347-34645	1 1/4	31.8	1 11/16-12	50.0	50.0	5.08	129.0	6.77	172.0	3.97	100.8
20GS-20FFORX90M	7347-33645	1 1/4	31.8	1 11/16-12	50.0	50.0	3.07	78.0	6.77	172.0	3.97	100.8
20GS-20FFORX90S	7347-32645	1 1/4	31.8	1 11/16-12	50.0	50.0	2.52	64.0	6.77	172.0	3.97	100.8
20GS-24FFORX90-064	7347-76985	1 1/4	31.8	2-12	50.0	60.0	2.52	64.0	6.77	172.0	3.97	100.8
24GSP-24FFORX90L	7347-34725	1 1/2	38.1	2-12	55.0	60.0	5.54	140.7	7.61	193.3	4.81	122.2
24GSP-24FFORX90M	7347-33725	1 1/2	38.1	2-12	55.0	60.0	3.41	86.6	7.61	193.3	4.81	122.2

GlobalSpiral™ 缠绕管分体式接头

SAE-61 轻型法兰接头

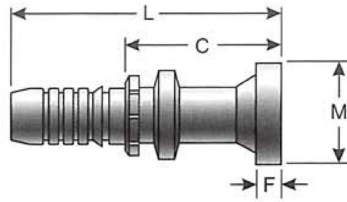

产品描述	编号	⊖		M		L		C		F	
		"	mm	"	mm	"	mm	"	mm	"	mm
6GS-8FL	7347-41155	3/8	9.5	1.19	30.2	3.54	89.9	2.13	54.1	.27	6.9
8GS-8FL	7347-41245	1/2	12.7	1.19	30.2	3.66	93.0	2.19	55.6	.27	6.9
8GS-12FL	7347-41265	1/2	12.7	1.50	38.1	3.86	98.1	2.38	60.5	.27	6.9
8GS-16FL	7347-41285	1/2	12.7	1.75	44.5	2.84	72.1	1.37	34.8	.32	8.1
10GS-12FL	7347-41355	5/8	15.9	1.50	38.1	4.29	109.0	2.31	58.7	.27	6.9
12GS-8FL	7347-41425	3/4	19.1	1.19	30.2	4.41	112.0	2.40	61.0	.27	6.9
12GS-12FL	7347-41445	3/4	19.1	1.50	38.1	4.37	111.0	2.36	59.9	.27	6.9
12GS-16FL	7347-41465	3/4	19.1	1.75	44.5	4.37	111.1	2.36	59.9	.32	8.1
12GS-20FL	7347-41475	3/4	19.1	2.00	50.8	4.37	111.0	2.36	59.9	.32	8.1
16GS-12FL	7347-41535	1	25.4	1.50	38.1	4.65	118.1	2.40	61.0	.27	6.9
16GS-16FL	7347-41555	1	25.4	1.75	44.5	4.92	125.0	2.70	68.6	.32	8.1
16GS-20FL	7347-41565	1	25.4	2.00	50.8	4.92	125.0	2.69	68.3	.32	8.1
16GS-24FL	7347-41575	1	25.4	2.38	60.5	4.92	125.0	1.90	48.3	.32	8.1
20GS-16FL	7347-41635	1 1/4	31.8	1.75	44.5	5.35	135.9	2.55	64.8	.32	8.1
20GS-20FL	7347-41645	1 1/4	31.8	2.00	50.8	5.75	146.1	2.95	74.9	.32	8.1
20GS-24FL	7347-41655	1 1/4	31.8	2.38	60.5	6.30	160.0	3.50	88.9	.32	8.1
20GS-32FL	7347-41665	1 1/4	31.8	2.81	71.4	5.71	145.0	2.91	73.9	.32	9.7
24GSP-20FL	7347-41715	1 1/2	38.1	2.00	50.8	5.74	145.8	2.85	72.4	.32	7.9
24GSP-24FL	7347-41725	1 1/2	38.1	2.38	60.5	6.02	152.9	3.12	79.3	.32	8.1
24GSP-32FL	7347-41735	1 1/2	38.1	2.81	71.4	5.79	147.1	2.99	76.0	.38	9.7
32GSP-24FL	7347-41785	2	50.8	2.38	60.5	6.53	165.9	2.49	63.3	.32	8.1
32GSP-32FL	7347-41795	2	50.8	2.81	71.4	6.27	159.3	2.65	67.3	.38	9.7
32GSP-40FL	7347-41805	2	50.8	3.31	84.1	8.52	216.4	2.99	76.0	.38	9.7

GlobalSpiral™ 缠绕管分体式接头

SAE-61 轻型法兰 22¹/₂°弯接头

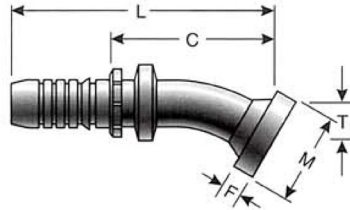

产品描述	编号	⊖		M		T		L		C		F	
		"	mm	"	mm	"	mm	"	mm	"	mm	"	mm
8GS-8FL22M	7347-42245	1/2	12.7	1.19	30.2	.35	8.9	3.78	96.0	2.30	58.4	.27	6.9
12GS-12FL22M	7347-42445	3/4	19.1	1.50	38.1	.43	10.9	5.16	131.1	3.15	80.0	.27	6.9
12GS-16FL22M	7347-42465	3/4	19.1	1.75	44.5	.55	14.0	5.24	133.1	3.23	82.0	.32	8.1
16GS-16FL22M	7347-42555	1	25.4	1.75	44.5	.55	14.0	6.10	154.9	3.87	98.3	.32	8.1
16GS-20FL22M	7347-42565	1	25.4	2.00	50.8	.59	15.0	6.61	167.9	4.37	111.0	.32	8.1
20GS-20FL22M	7347-42645	1 1/4	31.8	2.00	50.8	.59	15.0	7.01	178.1	4.21	106.9	.32	8.1
20GS-24FL22M	7347-42655	1 1/4	31.8	2.38	60.5	.71	18.0	7.32	185.9	4.52	114.8	.32	8.1
24GSP-24FL22M	7347-42725	1 1/2	38.1	2.38	60.5	.71	18.0	8.31	211.0	5.41	137.4	.32	8.1
24GSP-32FL22M	7347-42735	1 1/2	38.1	2.81	71.4	.87	22.1	8.43	214.1	8.43	214.1	.38	9.7
32GSP-32FL22M	7347-42795	2	50.8	2.81	71.4	.97	24.6	10.83	275.1	8.43	214.1	.38	9.7

SAE-61 轻型法兰 30°弯接头

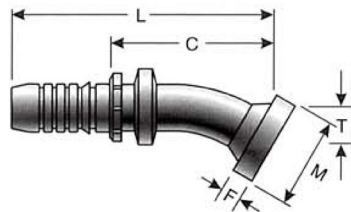

产品描述	编号	⊖		M		T		L		C		F	
		"	mm	"	mm	"	mm	"	mm	"	mm	"	mm
8GS-12FL30M	7347-43245	1/2	12.7	1.50	38.1	.63	16.0	3.94	100.1	2.46	62.5	.27	6.9
12GS-12FL30M	7347-43445	3/4	19.1	1.50	38.1	.63	16.0	5.08	129.0	3.07	78.0	.27	6.9
12GS-16FL30M	7347-43465	3/4	19.1	1.75	44.5	.75	19.1	4.76	120.9	2.76	70.1	.32	8.1
16GS-16FL30M	7347-43555	1	25.4	1.75	44.5	.75	19.1	6.02	152.9	3.80	96.5	.32	8.1
16GS-20FL30M	7347-43565	1	25.4	2.00	50.8	.87	22.1	6.54	166.1	4.29	109.0	.32	8.1
20GS-20FL30M	7347-43645	1 1/4	31.8	2.00	50.8	.87	22.1	6.93	176.0	4.13	104.9	.32	8.1
20GS-24FL30M	7347-43655	1 1/4	31.8	2.38	60.5	1.18	30.0	7.17	182.1	4.37	111.0	.32	8.1
24GSP-24FL30S	7347-43725	1 1/2	38.1	2.38	60.5	.98	24.9	8.23	209.0	5.31	134.9	.32	8.1
24GSP-32FL30M	7347-43735	1 1/2	38.1	2.81	71.4	1.26	32.0	8.27	210.1	5.39	136.9	.38	9.7
32GSP-32FL30M	7347-43795	2	50.8	2.81	71.4	1.25	31.8	10.70	271.8	7.10	180.3	.38	9.7

GlobalSpiral™ 缠绕管分体式接头

SAE-61 轻型法兰 45°弯接头

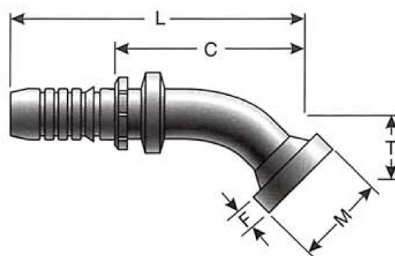

产品描述	编号	⊖		M		T		L		C		F	
		"	mm	"	mm	"	mm	"	mm	"	mm	"	mm
6GS-8FL45M	7347-44155	3/8	9.5	1.19	30.2	.75	19.1	3.66	93.0	2.25	57.2	.27	6.9
8GS-8FL45M	7347-44245	1/2	12.7	1.19	30.2	.75	19.1	3.70	94.0	2.22	56.4	.27	6.9
8GS-12FL45M	7347-44265	1/2	12.7	1.50	38.1	1.02	25.9	3.98	101.1	2.50	63.5	.27	6.9
10GS-12FL45M	7347-44355	5/8	15.9	1.50	38.1	1.02	25.9	5.00	127.0	3.02	76.7	.27	6.9
12GS-12FL45M	7347-44445	3/4	19.1	1.50	38.1	1.02	25.9	4.88	124.0	2.87	72.9	.27	6.9
12GS-16FL45S	7347-73135	3/4	19.1	1.75	44.5	1.10	27.9	4.96	126.0	2.95	74.9	.32	8.1
16GS-16FL45M	7347-44555	1	25.4	1.75	44.5	1.26	32.0	5.79	147.1	3.57	90.7	.32	8.1
16GS-20FL45M	7347-44565	1	25.4	2.00	50.8	1.50	38.1	6.22	158.0	3.97	100.8	.32	8.1
20GS-16FL45M	7347-44635	1 1/4	31.8	1.75	44.5	1.26	32.0	6.42	163.1	3.62	92.0	.32	8.1
20GS-20FL45S	7347-73565	1 1/4	31.8	2.00	50.8	1.26	32.0	6.69	169.9	3.89	98.8	.32	8.1
20GS-24FL45S	7347-73575	1 1/4	31.8	2.38	60.5	1.50	38.1	6.93	176.0	4.13	104.9	.32	8.1
24GSP-20FL45S	7347-44715	1 1/2	38.1	2.00	50.8	1.26	32.0	7.09	180.1	4.49	114.1	.32	8.1
24GSP-24FL45S	7347-44725	1 1/2	38.1	2.38	60.5	1.50	38.1	7.95	201.9	5.05	128.3	.32	8.1
24GSP-32FL45S	7347-44735	1 1/2	38.1	2.81	71.4	2.05	52.1	7.87	199.9	4.97	126.2	.38	9.7
32GSP-24FL45S	7347-44785	2	50.8	2.38	60.5	1.50	38.1	8.10	205.8	4.48	113.8	.32	8.1
32GSP-32FL45-066	7347-44805	2	50.8	2.81	71.4	2.60	66.0	10.12	257.1	6.50	165.1	.38	9.7

SAE-61 轻型法兰 60°弯接头

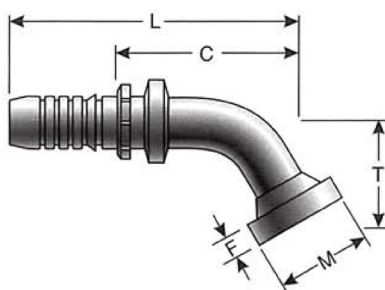

产品描述	编号	⊖		M		T		L		C		F	
		"	mm	"	mm	"	mm	"	mm	"	mm	"	mm
8GS-8FL60M	7347-45245	1/2	12.7	1.19	30.2	1.06	26.9	4.09	103.9	2.62	66.6	.27	6.9
12GS-12FL60M	7347-45445	3/4	19.1	1.50	38.1	1.46	37.1	5.39	136.9	3.39	86.1	.27	6.9
12GS-16FL60M	7347-45465	3/4	19.1	1.75	44.5	1.73	43.9	5.35	135.9	3.35	85.1	.32	8.1
16GS-16FL60M	7347-45555	1	25.4	1.75	44.5	1.73	43.9	6.18	157.0	3.97	100.8	.32	8.1
16GS-20FL60M	7347-45565	1	25.4	2.00	50.8	2.17	55.1	6.18	157.0	3.94	100.1	.32	8.1
20GS-20FL60M	7347-45645	1 1/4	31.8	2.00	50.8	2.17	55.1	7.36	186.9	4.56	115.8	.32	8.1
20GS-24FL60M	7347-45655	1 1/4	31.8	2.38	60.5	2.52	64.0	7.68	195.1	4.88	124.0	.32	8.1
24GSP-24FL60S	7347-45725	1 1/2	38.1	2.38	60.5	2.08	52.8	9.09	230.9	6.20	157.5	.32	8.1
24GSP-32FL60S	7347-45735	1 1/2	38.1	2.81	71.4	2.95	74.9	9.21	233.9	6.30	160.0	.38	9.7
32GSP-32FL60S	7347-45805	2	50.8	2.81	71.4	2.95	74.9	10.20	259.1	6.56	166.6	.38	9.7

GlobalSpiral™ 缠绕管分体式接头

SAE-61 轻型法兰 67°弯接头

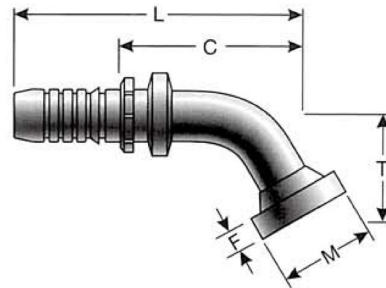

产品描述	编号	⊖		M		T		L		C		F	
		"	mm	"	mm	"	mm	"	mm	"	mm	"	mm
8GS-12FL67-032	7347-78025	1/2	12.7	1.50	38.1	1.26	32.0	3.70	94.0	2.21	56.1	.27	6.9
12GS-12FL67M	7347-46445	3/4	19.1	1.50	38.1	1.65	41.9	5.20	132.1	3.19	81.0	.27	6.9
12GS-16FL67M	7347-46465	3/4	19.1	1.75	44.5	2.01	51.1	5.08	129.0	3.07	78.0	.32	8.1
16GS-16FL67M	7347-46555	1	25.4	1.75	44.5	2.01	51.1	5.94	150.9	3.71	94.2	.32	8.1
16GS-20FL67M	7347-46565	1	25.4	2.00	50.8	2.52	64.0	5.83	148.1	3.59	91.2	.32	8.1
20GS-20FL67M	7347-46645	1 1/4	31.8	2.00	50.8	2.52	64.0	7.01	178.1	4.21	106.9	.32	8.1
20GS-24FL67S	7347-76605	1 1/4	31.8	2.38	60.5	2.01	51.1	6.46	164.1	3.66	93.0	.32	8.1
24GSP-24FL67S	7347-46725	1 1/2	38.1	2.38	60.5	2.40	61.0	8.90	226.1	5.90	149.9	.32	8.1
24GSP-32FL67S	7347-46735	1 1/2	38.1	2.81	71.4	3.33	84.6	10.20	259.1	5.90	149.9	.38	9.7
32GSP-32FL67S	7347-46795	2	50.8	2.81	71.4	3.84	97.5	10.20	259.1	6.56	166.6	.38	9.7

SAE-61 轻型法兰 90°弯接头

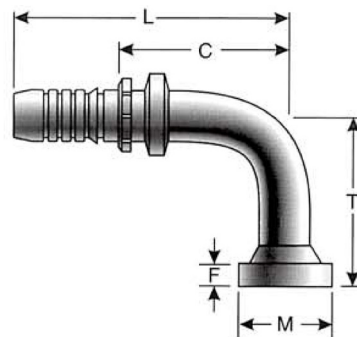

产品描述	编号	⊖		M		T		L		C		F	
		"	mm	"	mm	"	mm	"	mm	"	mm	"	mm
6GS-8FL90M	7347-74155	3/8	9.5	1.19	30.2	1.57	39.9	3.43	87.1	2.02	51.3	.27	6.9
8GS-8FL90L	7347-73815	1/2	12.7	1.19	30.2	3.27	83.1	3.46	87.9	1.99	50.6	.27	6.9
8GS-8FL90M	7347-74245	1/2	12.7	1.19	30.2	1.57	39.9	3.46	87.9	1.99	50.6	.27	6.9
8GS-12FL90M	7347-74265	1/2	12.7	1.50	38.1	2.28	57.9	3.46	87.9	1.98	50.3	.27	6.9
10GS-12FL90M	7347-74355	5/8	15.9	1.50	38.1	2.28	57.9	4.33	110.0	2.35	59.7	.27	6.9
12GS-12FL90-050	7347-76035	3/4	19.1	1.19	30.2	1.97	50.0	4.80	121.9	2.80	71.1	.27	6.9
12GS-12FL90-100	7347-73905	3/4	19.1	1.50	38.1	3.94	100.1	4.41	112.0	2.40	61.0	.27	6.9
12GS-12FL90-125	7347-73985	3/4	19.1	1.50	38.1	4.92	125.0	4.80	121.9	2.80	71.1	.27	6.9
12GS-12FL90M	7347-74445	3/4	19.1	1.50	38.1	2.28	57.9	4.41	112.0	2.40	61.0	.27	6.9
12GS-16FL90-080	7347-76085	3/4	19.1	1.75	44.5	3.15	80.0	5.04	128.0	3.03	77.0	.32	8.1

GlobalSpiral™ 缠绕管分体式接头

SAE-61 轻型法兰 90°弯接头

产品描述	编号	⊖		M		T		L		C		F	
		"	mm	"	mm	"	mm	"	mm	"	mm	"	mm
12GS-16FL90-090	7347-8579	3/4	19.1	1.75	44.5	3.54	90	4.57	116.0	2.56	65.0	.32	8.1
12GS-16FL90-100	7347-7627	3/4	19.1	1.75	44.5	3.93	100	4.57	116.0	2.56	65.0	.32	8.1
12GS-16FL90-110	7347-7949	3/4	19.1	1.75	44.5	4.33	110	4.57	116.0	2.56	65.0	.32	8.1
12GS-16FL90-130	7347-7936	3/4	19.1	1.75	44.5	5.11	130	4.57	116.0	2.56	65.0	.32	8.1
12GS-16FL90-150	7347-7628	3/4	19.1	1.75	44.5	5.91	150	4.57	116.0	2.56	65.0	.32	8.1
12GS-16FL90-178	7347-79025	3/4	19.1	1.75	44.5	7.01	178.1	4.41	134.0	2.38	77.2	.32	8.1
12GS-16FL90M	7347-73925	3/4	19.1	1.75	44.5	2.76	70.1	4.41	112.0	2.40	61.0	.32	8.1
12GS-16FL90S	7347-73915	3/4	19.1	1.75	44.5	2.40	61.0	4.41	112.0	2.40	61.0	.32	8.1
12GS-20FL90-054	7347-73995	3/4	19.1	2.00	50.8	2.13	54.1	5.16	131.1	3.15	80.0	.32	8.1
12GS-20FL90-125	7347-78375	3/4	19.1	2.00	50.8	4.92	125.0	4.76	120.9	2.76	70.1	.32	8.1
16GS-16FL90-090	7347-7839	1	25.4	1.75	44.5	3.54	90	5.28	134.0	3.04	77.2	.32	8.1
16GS-16FL90-110	7347-7950	1	25.4	1.75	44.5	4.33	110	5.28	134.0	3.04	77.2	.32	8.1
16GS-16FL90-130	7347-7937	1	25.4	1.75	44.5	5.11	130	5.28	134.0	3.04	77.2	.32	8.1
16GS-16FL90-140	7347-8509	1	25.4	1.75	44.5	5.51	140	5.28	134.0	3.04	77.2	.32	8.1
16GS-16FL90-150	7347-7870	1	25.4	1.75	44.5	5.91	150	5.28	144.0	3.44	87.4	.32	8.1
16GS-16FL90-160	7347-7322	1	25.4	1.75	44.5	6.30	160	5.28	134.0	3.04	77.2	.32	8.1
16GS-16FL90-180	7347-8519	1	25.4	1.75	44.5	7.09	180	5.28	134.0	3.04	77.2	.32	8.1
16GS-12FL90	7347-73255	1	25.4	1.50	38.1	3.15	80.0	5.31	134.9	3.10	78.7	.27	6.9
16GS-12FL90M	7347-74535	1	25.4	1.50	38.1	2.28	57.9	5.31	134.9	5.08	129.0	.27	6.9
16GS-16FL90-120	7347-73165	1	25.4	1.75	44.5	4.72	119.9	5.28	134.1	3.04	77.2	.32	8.1
16GS-16FL90-210	7347-78875	1	25.4	1.75	44.5	8.27	210.1	5.28	134.1	3.02	76.7	.32	8.1
16GS-16FL90M	7347-74555	1	25.4	1.75	44.5	2.76	70.1	5.31	134.9	3.09	78.5	.32	8.1
16GS-16FL90S	7347-47555	1	25.4	1.75	44.5	2.40	61.0	5.31	134.9	3.09	78.5	.32	8.1
16GS-20FL90M	7347-74565	1	25.4	2.00	50.8	3.54	89.9	5.28	134.1	2.99	76.0	.32	8.1
16GS-20FL90S	7347-47565	1	25.4	2.00	50.8	2.68	68.1	5.28	134.1	3.02	76.7	.32	8.1
16GS-24FL90-060	7347-73975	1	25.4	2.38	60.5	2.36	59.9	5.71	145.0	3.47	88.1	.32	8.1
16GS-24FL90S	7347-47575	1	25.4	2.38	60.5	3.19	81.0	5.28	134.1	3.04	77.2	.32	8.1
20GS-16FL90-215	7347-78885	1 1/4	31.8	1.75	44.5	8.46	214.9	6.30	160.0	3.50	88.9	.32	8.1
20GS-16FL90M	7347-74635	1 1/4	31.8	1.75	44.5	2.76	70.1	6.30	160.0	3.50	88.9	.32	8.1
20GS-20FL90-168	7347-76105	1 1/4	31.8	2.00	50.8	6.61	167.9	6.54	166.1	3.74	95.0	.32	8.1
20GS-20FL90M	7347-74645	1 1/4	31.8	2.00	50.8	3.54	89.9	6.50	165.1	3.70	94.0	.32	8.1
20GS-20FL90S	7347-47645	1 1/4	31.8	2.00	50.8	2.68	68.1	6.50	165.1	3.70	94.0	.32	8.1
20GS-24FL90-118	7347-76085	1 1/4	31.8	2.38	60.5	4.65	118.1	6.50	165.1	3.70	94.0	.32	8.1
20GS-24FL90S	7347-47655	1 1/4	31.8	2.38	60.5	3.19	81.0	6.50	165.1	3.70	94.0	.32	8.1
24GSP-20FL90S	7347-47715	1 1/2	38.1	2.00	50.8	2.68	68.1	6.81	173.0	3.92	99.6	.32	8.1
24GSP-24FL90-148	7347-85625	1 1/2	38.1	2.36	59.9	5.83	148.1	6.89	175.0	4.01	101.9	.32	8.1
24GSP-24FL90M	7347-74725	1 1/2	38.1	2.36	59.9	4.09	103.9	6.89	175.0	4.01	101.9	.32	8.1
24GSP-24FL90S	7347-47725	1 1/2	38.1	2.38	60.5	3.19	81.0	7.24	183.9	4.33	110.0	.32	8.1
24GSP-32FL90-080	7347-47745	1 1/2	38.1	2.81	71.4	3.15	80.0	6.99	177.6	4.01	101.9	.38	9.7
24GSP-32FL90-170	7347-85435	1 1/2	38.1	2.81	71.4	6.69	169.9	6.88	174.8	3.99	101.4	.38	9.7
24GSP-32FL90S	7347-47735	1 1/2	38.1	2.81	71.4	4.72	119.9	6.90	175.3	4.01	101.9	.38	9.7
32GSP-24FL90S	7347-47785	2	50.8	2.36	59.9	3.19	81.0	7.76	197.1	4.13	104.9	.31	7.9
32GSP-32FL90-114	7347-47805	2	50.8	2.81	71.4	4.49	114.1	8.74	222.0	5.12	130.1	.38	9.7
32GSP-32FL90-165	7347-85425	2	50.8	2.81	71.4	6.50	165.1	9.69	246.1	6.06	153.9	.38	9.7
32GSP-32FL90-200	7347-85455	2	50.8	2.81	71.4	7.97	202.4	8.74	222.0	5.13	130.3	.38	9.7
32GSP-40FL90-110	7347-74805	2	50.8	3.31	84.1	4.38	111.3	8.52	216.4	4.98	126.5	.38	9.7

GlobalSpiral™ 缠绕管分体式接头

SAE-61 轻型法兰 110°弯接头

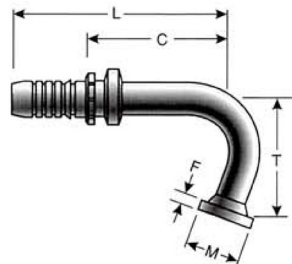

产品描述	编号	⊖		M		T		L		C		F	
		"	mm	"	mm	"	mm	"	mm	"	mm	"	mm
12GS-12FL110-064	7347-76025	3/4	19.1	1.50	38.1	2.52	64.0	5.16	131.1	3.15	80.0	.27	6.9
16GS-16FL110-073	7347-73005	1	25.4	1.75	44.5	2.87	72.9	5.83	148.1	3.61	91.7	.32	8.1
16GS-20FL110-073	7347-76455	1	25.4	2.00	50.8	2.87	72.9	4.65	118.1	2.41	61.2	.32	8.1
20GS-20FL110-080	7347-76115	1 1/4	31.8	2.00	50.8	3.15	80.0	7.13	181.1	4.33	110.0	.32	8.1
20GS-24FL110-080	7347-76125	1 1/4	31.8	2.38	60.5	3.15	80.0	7.13	181.1	4.33	110.0	.32	8.1
24GS-24FL110-094	7347-85635	1 1/2	38.1	2.36	59.9	3.70	94.0	7.95	201.9	5.07	128.8	.31	7.9
32GS-32FL110-140	7347-85465	2	50.8	2.81	71.4	3.51	89.2	9.80	248.9	6.40	162.6	.38	9.7

SAE-61 轻型法兰 135°弯接头

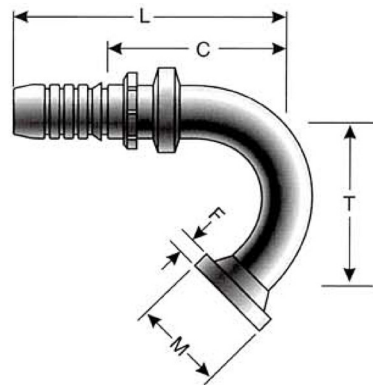

产品描述	编号	⊖		M		T		L		C		F	
		"	mm	"	mm	"	mm	"	mm	"	mm	"	mm
12GS-12FL135-070	7347-76825	3/4	19.1	1.50	38.1	2.76	70.1	3.82	97.0	1.81	46.0	.27	6.9

SAE-62 重型法兰接头

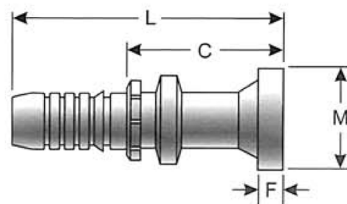

GlobalSpiral™ 缠绕管分体式接头

产品描述	编号	⊖		M		L		C		F	
		"	mm	"	mm	"	mm	"	mm	"	mm
8GS-8FLH	7347-48245	1/2	12.7	1.25	31.8	3.66	93.0	2.19	55.6	.31	7.9
8GS-12FLH	7347-48265	1/2	12.7	1.63	41.4	3.66	93.0	2.19	55.6	.35	8.9
10GS-8FLH	7347-48335	5/8	15.9	1.25	31.8	4.29	109.0	2.31	58.7	.31	7.9
10GS-12FLH	7347-48355	5/8	15.9	1.63	41.4	4.29	109.0	2.31	58.7	.35	8.9
12GS-12FLH	7347-48445	3/4	19.1	1.63	41.4	4.49	114.1	2.48	63.0	.35	8.9
12GS-16FLH	7347-48465	3/4	19.1	1.88	47.8	4.49	114.1	2.48	63.0	.38	9.7
16GS-12FLH	7347-48535	1	25.4	1.63	41.4	5.08	129.0	2.86	72.6	.35	8.9
16GS-16FLH	7347-48555	1	25.4	1.88	47.8	4.92	125.0	2.70	68.6	.38	9.7
16GS-20FLH	7347-48565	1	25.4	2.13	54.1	4.92	125.0	2.69	68.3	.41	10.4
20GS-16FLH	7347-48635	1 1/4	31.8	1.88	47.8	6.42	163.1	3.62	92.0	.38	9.7
20GS-20FLH	7347-48645	1 1/4	31.8	2.13	54.1	5.75	146.1	2.95	74.9	.41	10.4
20GS-24FLH	7347-48655	1 1/4	31.8	2.50	63.5	6.30	160.0	3.50	88.9	.50	12.7
24GSP-24FLH	7347-48725	1 1/2	38.1	2.50	63.5	6.57	166.9	3.68	93.5	.50	12.7
24GSP-32FLH	7347-48735	1 1/2	38.1	3.13	79.5	6.57	166.9	3.68	93.5	.50	12.7
32GSP-32FLH	7347-48795	2	50.8	3.13	79.5	7.09	180.1	3.46	87.9	.50	12.7

SAE-62 重型法兰 22¹/₂°弯接头

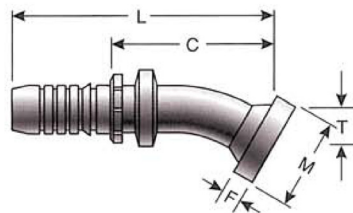

产品描述	编号	⊖		M		T		L		C		F	
		"	mm	"	mm	"	mm	"	mm	"	mm	"	mm
12GS-16FLH22M	7347-49465	3/4	19.1	1.88	47.8	.55	14.0	5.43	137.9	3.43	87.1	.38	9.7
16GS-16FLH22M	7347-49555	1	25.4	1.88	47.8	.55	14.0	6.10	154.9	3.88	98.6	.38	9.7
16GS-20FLH22M	7347-49565	1	25.4	2.13	54.1	.59	15.0	6.61	167.9	4.52	114.8	.41	10.4
20GS-20FLH22M	7347-49645	1 1/4	31.8	2.13	54.1	.59	15.0	7.32	185.9	4.52	114.8	.41	10.4
20GS-24FLH22M	7347-49655	1 1/4	31.8	2.50	63.5	.71	18.0	7.40	188.0	4.60	116.8	.50	12.7

SAE-62 重型法兰 30°弯接头

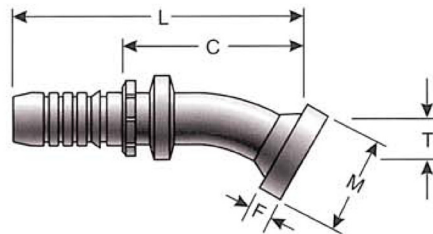

产品描述	编号	⊖		M		T		L		C		F	
		"	mm	"	mm	"	mm	"	mm	"	mm	"	mm
12GS-12FLH30M	7347-50445	3/4	19.1	1.63	41.4	.63	16.0	5.08	129.0	3.07	78.0	.35	8.9
12GS-16FLH30M	7347-50465	3/4	19.1	1.88	47.8	.75	19.1	5.08	129.0	3.07	78.0	.38	9.7
16GS-16FLH30M	7347-50555	1	25.4	1.88	47.8	.75	19.1	6.02	152.9	3.80	96.5	.38	9.7
16GS-20FLH30M	7347-50565	1	25.4	2.13	54.1	1.50	38.1	6.22	158.0	3.98	101.1	.41	10.4
20GS-20FLH30M	7347-50645	1 1/4	31.8	2.13	54.1	.87	22.1	7.24	183.9	4.44	112.8	.41	10.4
20GS-24FLH30M	7347-50655	1 1/4	31.8	2.50	63.5	1.18	30.0	7.24	183.9	4.44	112.8	.50	12.7

GlobalSpiral™ 缠绕管分体式接头

SAE-61 重型法兰 45°弯接头

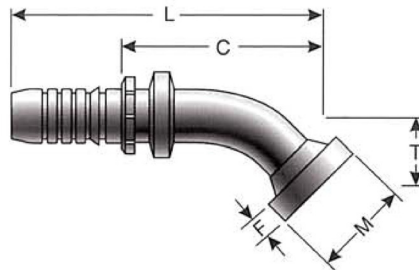

产品描述	编号	⊖		M		T		L		C		F	
		"	mm	"	mm	"	mm	"	mm	"	mm	"	mm
8GS-8FLH5M	7347-51245	1/2	12.7	1.25	31.8	.75	19.1	3.70	94.0	2.22	56.4	.31	7.9
8GS-12FLH22M	7347-51265	1/2	12.7	1.63	41.4	1.02	25.9	3.98	101.1	2.50	63.5	.35	8.9
10GS-12FLH45M	7347-51355	5/8	15.9	1.63	41.4	1.02	25.9	5.00	127.0	3.02	76.7	.35	8.9
12GS-8FLH45M	7347-51425	3/4	19.1	1.25	31.8	.75	19.1	4.56	115.8	2.55	64.8	.31	7.9
12GS-12FLH45M	7347-51445	3/4	19.1	1.63	41.4	1.02	25.9	4.88	124.0	2.87	72.9	.35	8.9
12GS-16FLH45M	7347-51465	3/4	19.1	1.88	47.8	1.26	32.0	5.12	130.1	3.11	79.0	.38	9.7
16GS-12FLH45M	7347-51535	1	25.4	1.63	41.4	1.02	25.9	5.55	141.0	3.33	84.6	.35	8.9
16GS-16FLH45M	7347-51555	1	25.4	1.88	47.8	1.26	32.0	5.79	147.1	3.57	90.7	.38	9.7
16GS-20FLH45M	7347-51565	1	25.4	2.13	54.1	1.50	38.1	6.22	158.0	3.98	101.1	.41	10.4
20GS-16FLH45M	7347-51635	1 1/4	31.8	1.88	47.8	1.26	32.0	6.73	170.9	3.93	99.8	.38	9.7
20GS-20FLH45M	7347-51645	1 1/4	31.8	2.13	54.1	1.50	38.1	6.93	176.0	4.13	104.9	.41	10.4
20GS-24FLH45M	7347-51655	1 1/4	31.8	2.50	63.5	1.73	43.9	6.93	176.0	4.13	104.9	.50	12.7
24GSP-24FLH45M	7347-51725	1 1/2	38.1	2.50	63.5	1.73	43.9	7.56	192.0	4.65	118.1	.50	12.7
24GSP-32FLH45S	7347-51735	1 1/2	38.1	3.13	79.5	2.05	52.1	7.87	199.9	4.98	126.5	.50	12.7
32GSP-32FLH45-066	7347-51805	2	50.8	3.13	79.5	2.60	66.0	10.67	271.0	7.06	179.3	.50	12.7

SAE-62 重型法兰 60°弯接头

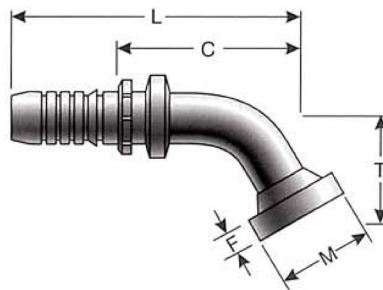

产品描述	编号	⊖		M		T		L		C		F	
		"	mm	"	mm	"	mm	"	mm	"	mm	"	mm
12GS-12FLH60M	7347-52445	3/4	19.1	1.63	41.4	1.46	37.1	5.39	136.9	3.39	86.1	.35	8.9
12GS-16FLH60M	7347-52465	3/4	19.1	1.88	47.8	1.73	43.9	5.35	135.9	3.35	85.1	.38	9.7
16GS-16FLH60M	7347-52555	1	25.4	1.88	47.8	1.73	43.9	6.18	157.0	3.96	100.6	.38	9.7
20GS-20FLH60M	7347-52645	1 1/4	31.8	2.13	54.1	2.17	55.1	7.32	185.9	4.52	114.8	.41	10.4
20GS-24FLH60M	7347-52655	1 1/4	31.8	2.50	63.5	2.52	64.0	7.64	194.1	4.84	122.9	.50	12.7

GlobalSpiral™ 缠绕管分体式接头

SAE-62 重型法兰 90°弯接头

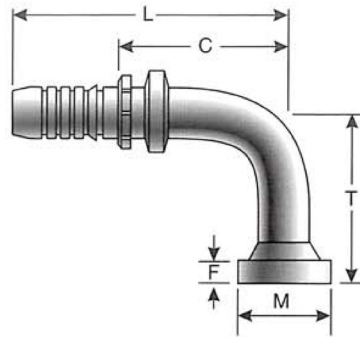

产品描述	编号	⊖		M		T		L		C		F	
		"	mm	"	mm	"	mm	"	mm	"	mm	"	mm
8GS-8FLH90-080	7347-73825	1/2	12.7	1.25	31.8	3.15	80.0	3.46	87.9	1.99	50.6	.31	7.9
8GS-8FLH90M	7347-75245	1/2	12.7	1.25	31.8	1.57	39.9	3.46	87.9	1.99	50.6	.31	7.9
8GS-12FLH90M	7347-75265	1/2	12.7	1.63	41.4	2.28	57.9	3.46	87.9	1.99	50.6	.35	8.9
10GS-8FLH90M	7347-75335	5/8	15.9	1.25	31.8	1.57	39.9	4.45	113.0	2.47	62.7	.31	7.9
10GS-12FLH90M	7347-75355	5/8	15.9	1.63	41.4	2.28	57.9	4.33	111.0	2.35	59.7	.35	8.9
12GS-12FLH90-100	7347-73835	3/4	19.1	1.63	41.4	3.94	100.1	4.41	112.0	2.40	61.0	.35	8.9
12GS-12FLH90-122	7347-76415	3/4	19.1	1.63	41.4	4.80	121.9	4.80	121.9	2.80	71.1	.35	8.9
12GS-12FLH90M	7347-75445	3/4	19.1	1.63	41.4	2.28	57.9	4.41	112.0	2.40	61.0	.35	8.9
12GS-16FLH90-100	7347-76715	3/4	19.1	1.88	47.8	5.51	140.0	4.57	116.1	2.56	65.0	.38	9.7
12GS-16FLH90M	7347-73935	3/4	19.1	1.88	47.8	2.76	70.1	4.41	112.0	2.40	61.0	.38	9.7
12GS-16FLH90S	7347-54465	3/4	19.1	1.88	47.8	2.40	61.0	4.41	112.0	2.40	61.0	.38	9.7
12GS-20FLH90M	7347-75475	3/4	19.1	2.13	54.1	3.54	89.9	4.80	121.9	2.80	71.1	.41	10.4
16GS-12FLH90M	7347-54535	1	25.4	1.63	41.4	2.28	57.9	5.31	134.9	3.09	78.5	.35	8.9
16GS-16FLH90-090	7347-78105	1	25.4	1.88	47.8	3.54	89.9	5.52	140.2	3.28	83.3	.38	9.7
16GS-16FLH90-110	7347-7722	1	25.4	1.88	47.8	4.33	110	5.28	134.0	3.04	77.2	.38	9.7
16GS-16FLH90-120	7347-73015	1	25.4	1.88	47.8	4.72	119.9	5.28	134.1	3.04	77.2	.38	9.7
16GS-16FLH90-130	A1-SZ-008	1	25.4	1.88	47.8	5.12	130	5.28	134.0	3.04	77.2	.38	9.7
16GS-16FLH90-160	7347-7339	1	25.4	1.88	47.8	6.30	160	5.28	134.0	3.04	77.2	.38	9.7
16GS-16FLH90M	7347-75555	1	25.4	1.88	47.8	2.76	70.1	5.31	134.9	3.09	78.5	.38	9.7
16GS-16FLH90S	7347-54555	1	25.4	1.88	47.8	2.40	61.0	5.31	134.9	3.09	78.5	.38	9.7
16GS-20FLH90M	7347-75565	1	25.4	2.13	54.1	3.54	89.9	5.28	134.1	3.02	76.7	.41	10.4
16GS-20FLH90S	7347-54565	1	25.4	2.13	54.1	2.68	68.1	5.28	134.1	3.02	76.7	.41	10.4
16GS-20FLH90-110	7347-7965	1	25.4	2.13	54.1	4.33	110	5.28	134.0	3.04	77.2	.38	9.7
16GS-20FLH90-130	A16-SZ-004	1	25.4	2.13	54.1	6.30	130	5.28	134.0	3.04	77.2	.41	10.4
16GS-20FLH90-150	7347-8574	1	25.4	2.13	54.1	5.91	150	5.28	134.0	3.04	77.2	.41	10.4
16GS-20FLH90-165	7347-7963	1	25.4	2.13	54.1	6.50	165	5.28	134.0	3.04	77.2	.41	10.4
16GS-20FLH90-180	7347-8567	1	25.4	2.50	54.1	3.19	180	5.28	134.0	3.04	77.2	.50	10.4
20GS-16FLH90-100	7347-76185	1 1/4	31.8	1.88	47.8	3.94	100.1	6.30	160.0	3.50	88.9	.38	9.7
20GS-16FLH90M	7347-75635	1 1/4	31.8	1.88	47.8	2.76	70.1	6.30	160.0	3.50	88.9	.38	9.7
20GS-16FLH90S	7347-54635	1 1/4	31.8	1.88	47.8	2.40	61.0	6.30	160.0	3.50	88.9	.38	9.7
20GS-20FLH90-076	7347-73635	1 1/4	31.8	2.13	54.1	2.99	76.0	6.50	165.1	3.70	94.0	.41	10.4
20GS-20FLH90-120	7347-76135	1 1/4	31.8	2.13	54.1	4.72	119.9	6.50	165.1	3.70	94.0	.41	10.4
20GS-20FLH90-152	7347-76485	1 1/4	31.8	2.13	54.1	5.98	151.9	6.50	165.1	3.70	94.0	.41	10.4
20GS-20FLH90-180	73478526	1 1/4	31.8	2.13	54.1	7.09	180	6.50	165.0	3.70	94.0	.41	10.4
20GS-20FLH90-200	73477843	1 1/4	31.8	2.13	54.1	7.87	200	6.50	165.0	3.70	94.0	.41	10.4
20GS-20FLH90M	7347-75645	1 1/4	31.8	2.13	54.1	3.54	89.9	6.50	165.1	3.70	94.0	.41	10.4
20GS-24FLH90S	7347-75655	1 1/4	31.8	2.50	63.5	3.19	81.0	6.50	165.1	3.70	94.0	.50	12.7
24GSP-24FLH90-094	7347-79105	1 1/2	38.1	2.50	63.5	3.70	94.0	6.91	175.5	4.01	101.9	.50	12.7
24GSP-32FLH90S	7347-54735	1 1/2	38.1	3.13	79.5	4.72	119.9	6.96	176.8	4.06	103.1	.49	12.5
32GSP-32FLH90M	7347-75795	2	50.8	3.13	79.5	5.40	137.2	8.72	221.5	5.09	129.3	.50	12.7

GlobalSpiral™ 缠绕管分体式接头

BSP 直管外螺纹直接头

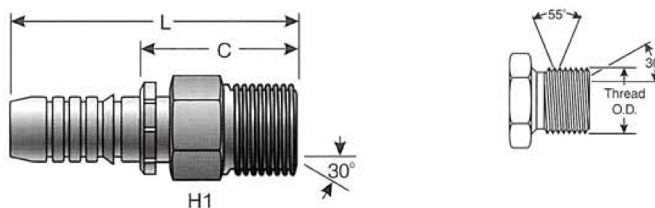

产品描述	编号	⊖		🌀	H1	H2	L		C	
		"	mm				"	mm	"	mm
6GS-6MBSPP	7347-01775	3/8	9.5	3/8-19	22.0	—	2.48	63.0	1.07	27.2
8GS-8MBSPP	7347-91365	1/2	12.7	1/2-14	27.0	—	2.66	67.6	1.81	46.0
10GS-10MBSPP	7347-92615	5/8	15.9	5/8-14	30.0	—	2.66	67.6	1.18	30.0
10GS-12MBSPP	7347-92625	5/8	15.9	3/4-14	32.0	—	3.35	85.1	1.37	34.8
12GS-12MBSPP	7347-92205	3/4	19.1	3/4-14	32.0	—	3.35	85.1	1.37	34.8
16GS-16MBSPP	7347-90825	1	25.4	1-11	41.0	—	3.86	98.1	1.62	41.2
20GS-20MBSPP	7347-93365	1 1/4	31.8	1 1/4-11	50.0	—	4.65	118.1	1.85	47.0

BSP 直管内螺纹 60°锥带 O 型圈直接头

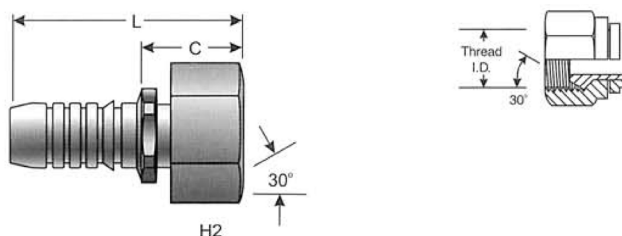

产品描述	编号	⊖		🌀	H1	H2	L		C	
		"	mm				"	mm	"	mm
6GS-6FBSPORX	7347-92235	3/8	9.5	3/8-19	—	22.0	2.34	59.4	.93	23.6
6GS-8FBSPORX	7347-92705	3/8	9.5	1/2-14	—	27.0	2.40	61.0	.93	23.6
8GS-8FBSPORX	7347-91405	1/2	12.7	1/2-14	—	27.0	2.40	61.0	.93	23.6
10GS-10FBSPORX	7347-92405	5/8	15.9	5/8-14	—	30.0	3.35	85.1	1.18	30.0
10GS-12FBSPORX	7347-93965	5/8	15.9	3/4-14	—	30.0	3.35	85.1	1.37	34.8
12GS-12FBSPORX	7347-93995	3/4	19.1	3/4-14	—	32.0	3.41	86.6	1.40	35.6
12GS-16FBSPORX	7347-92585	3/4	19.1	1-11	—	41.0	3.74	95.0	1.40	35.6
16GS-16FBSPORX	7347-90815	1	25.4	1-11	—	41.0	3.74	95.0	1.52	38.6
16GS-20FBSPORX	7347-94195	1	25.4	1 1/2	—	50.0	3.27	83.1	1.03	26.2
20GS-20FBSPORX	7347-93375	1 1/4	31.8	1 1/4-11	—	50.0	4.59	116.6	1.79	45.5
24GSP-24FBSPORX	7347-95025	1 1/2	38.1	1 1/2-11	—	55.0	4.92	125.0	2.01	51.1
32GSP-32FBSPORX	7347-95105	2	50.8	2	—	70.0	5.98	151.9	2.36	59.9

GlobalSpiral™ 缠绕管分体式接头

BSP 直管内螺纹 60°锥带 O 型圈 45°弯接头

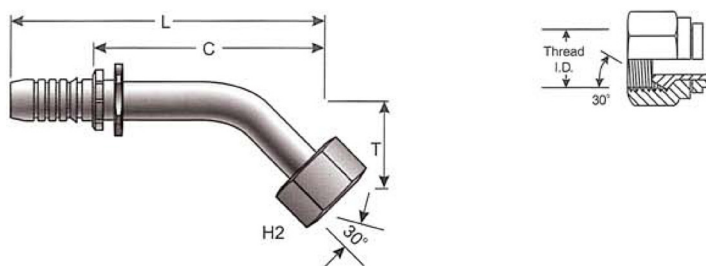

产品描述	编号	⊖			H1	H2	T		L		C	
		"	mm				"	mm	"	mm	"	mm
6GS-6FBSPORX45M	7347-92345	3/8	9.5	3/8-19	—	22.0	.61	15.5	3.27	83.1	1.86	47.2
8GS-8FBSPORX45M	7347-91415	1/2	12.7	1/2-14	—	27.0	.67	17.0	3.60	91.4	2.13	54.1
10GS-10FBSPORX45	7347-92285	5/8	15.9	5/8-14	—	30.0	1.04	26.4	4.20	106.7	2.25	57.2
12GS-12FBSPORX45M	7347-92245	3/4	19.1	3/4-14	—	32.0	1.11	28.2	5.29	134.4	3.28	83.3
16GS-16FBSPORX45M	7347-92275	1	25.4	1-11	—	41.0	1.22	31.0	6.12	155.5	3.90	99.1
20GS-20FBSPORX45M	7347-93395	1 1/4	31.8	1 1/4-11	—	50.0	1.48	37.6	7.52	191.0	4.72	119.9
24GSP-24FBSPORX45	7347-95035	1 1/2	38.1	1 1/2-11	—	55.0	1.96	49.8	8.44	214.4	5.54	140.7
32GSP-32FBSPORX45	7347-95115	2	50.8	2-11	—	70.0	2.45	62.2	10.87	276.1	7.24	183.9

BSP 直管内螺纹 60°锥带 O 型圈 90°弯接头

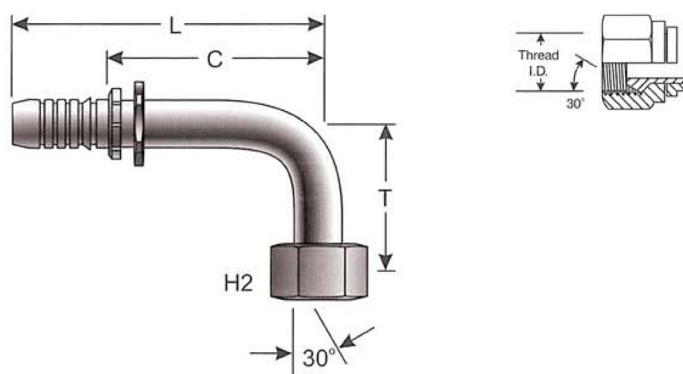

产品描述	编号	⊖			H1	H2	T		L		C	
		"	mm				"	mm	"	mm	"	mm
6GS-6FBSPORX90M	7347-92355	3/8	9.5	3/8-19	—	22.0	1.26	32.0	3.07	78.0	1.66	42.2
8GS-8FBSPORX90M	7347-91425	1/2	12.7	1/2-14	—	27.0	1.48	37.6	3.46	87.9	1.99	50.6
10GS-10FBSPORX90	7347-92295	5/8	15.9	5/8-14	—	30.0	1.90	48.3	4.70	119.4	2.45	62.2
12GS-12FBSPORX90M	7347-92225	3/4	19.1	3/4-14	—	32.0	2.36	59.9	4.86	123.4	2.85	72.4
16GS-16FBSPORX90M	7347-92785	1	25.4	1-11	—	41.0	2.76	70.1	5.81	147.6	3.59	91.2
20GS-20FBSPORX90M	7347-93405	1 1/4	31.8	1 1/4-11	—	50.0	3.15	80.0	7.11	180.6	4.31	109.5
24GSP-24FBSPORX90	7347-95045	1 1/2	38.1	1 1/2-11	—	55.0	3.93	99.8	7.66	194.6	4.75	120.7
32GSP-32FBSPORX90	7347-95125	2	50.8	2-11	—	70.0	5.08	129.0	10.02	254.5	6.40	162.6

GlobalSpiral™ 缠绕管分体式扣套

GS 分体式接头扣套—编织管

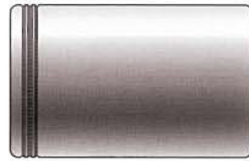

产品描述	编号	⊖		L		⊙	
		"	mm	"	mm	"	mm
6GS1F-1	7347-02875	3/8	9.5	1.20	30.5	.96	24.4
6GS1F-2	7347-02945	3/8	9.5	1.20	30.5	1.06	26.9
8GS1F-2	7347-02955	1/2	12.7	1.47	37.3	1.15	29.2
10GS1F-2	7347-02965	5/8	15.9	1.40	35.6	1.33	33.8
12GS1F-2	7347-02975	3/4	19.1	1.73	44.0	1.57	39.9
16GS1F-2	7347-02985	1	25.4	2.06	52.3	1.94	49.3
20GS1F-2	7347-02995	1 1/4	31.8	2.41	61.2	2.37	60.2

GSP 分体式接头扣套—编织管



产品描述	编号	⊖		L		⊙	
		"	mm	"	mm	"	mm
24GSP1F-2	7347-03165	1 1/2	38.1	2.98	75.7	2.76	70.1
32GSP1F-2	7347-03185	2	50.8	3.54	89.9	3.29	83.6

GS 分体式接头扣套—四层缠绕管



产品描述	编号	⊖		L		⊙	
		"	mm	"	mm	"	mm
6GS1F-4	7347-03105	3/8	9.5	1.43	36.3	1.25	31.8
8GS1F-4	7347-03115	1/2	12.7	1.44	36.9	1.35	34.3
10GS1F-4	7347-03125	5/8	15.9	1.88	47.8	1.64	41.7
12GS1F-4	7347-03135	3/4	19.1	2.00	50.8	1.80	45.7
16GS1F-4	7347-03145	1	25.4	2.22	56.4	2.07	52.6
20GS1F-4	7347-03155	1 1/4	31.8	2.67	67.8	2.42	61.5

GlobalSpiral™ 缠绕管分体式扣套

GSP 分体式接头扣套—四层缠绕管

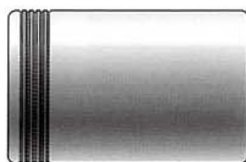

产品描述	编号	⊖		L		⊘	
		"	mm	"	mm	"	mm
24GSP1F-4	7347-03175	1 1/2	38.1	3.01	76.5	2.83	71.9
32GSP1F-4	7347-03195	2	50.8	3.58	90.9	3.35	85.1

GS 分体式接头扣套—六层缠绕管

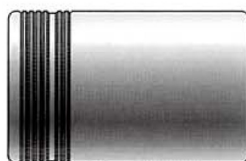

产品描述	编号	⊖		L		⊘	
		"	mm	"	mm	"	mm
20GSP1F-6	7347-02905	1 1/4	31.8	2.87	72.9	2.67	67.8

GlobalSpiral™ 缠绕管一体式接头

公制 24°锥内螺纹带 O 型圈重系列直接头

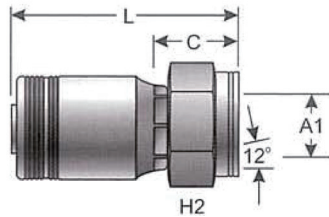

产品描述	编号	⊖			H1	H2	L		C		A1
		"	mm		mm	mm	"	mm	"	mm	mm
24GSM-38FDHORX	7341-07055	1 1/2	38.1	M52X2.0	—	60.0	7.09	180.1	3.35	85.1	38.0

公制 24°锥内螺纹带 O 型圈重系列 45°弯接头

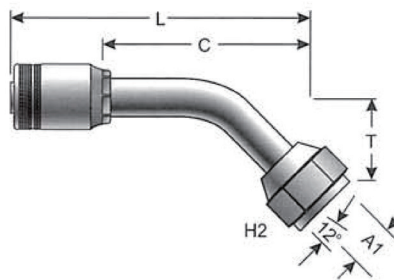

产品描述	编号	⊖			H1	H2	T	L		C		A1	
		"	mm		mm	mm	"	mm	"	mm	mm	mm	
24GSM-38FDHORX45	7341-07065	1 1/2	38.1	M52X2.0	—	60.0	1.74	44.2	9.33	237.0	5.59	142.0	38.0

公制 24°锥内螺纹带 O 型圈重系列 90°弯接头

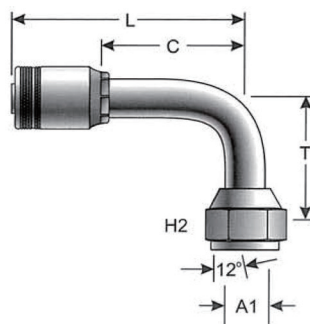

产品描述	编号	⊖			H1	H2	T	L		C		A1	
		"	mm		mm	mm	"	mm	"	mm	mm	mm	
24GSM-38FDHORX90	7341-07075	1 1/2	38.1	M52X2.0	—	60.0	3.62	92.0	8.76	222.5	5.02	127.5	38.0

GlobalSpiral™ 缠绕管一体式接头

JIC 37°外螺纹直接头

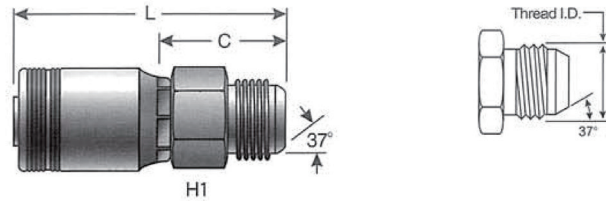

产品描述	编号	⊖			H1	H2	L		C	
		"	mm		"	"	"	mm	"	mm
24GSM-24MJ	7341-02555	1 1/2	38.1	1 7/8-12	1.97	—	6.39	162.3	2.65	67.3
32GSM-32MJ	7341-20465	2	50.8	2 1/2-12	2.56	—	7.72	196.1	3.24	82.3

NPTF 锥管外螺纹直接头

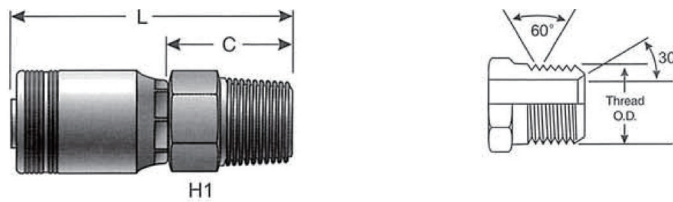

Do Not Use in Oil Field (API) Connections

产品描述	编号	⊖			H1	H2	L		C	
		"	mm		"	"	"	mm	"	mm
24GSM-24MP	7341-02585	1 1/2	38.1	1 1/2-11	2	—	6.51	165.4	2.77	70.4
32GSM-32MP	7341-20405	2	50.8	2-11 1/2	2.75	—	7.54	191.5	3.05	77.5

NPTF 锥管外螺纹直接头 -API

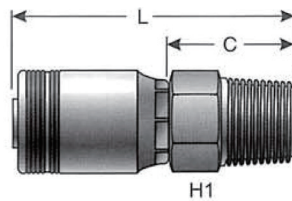

产品描述	编号	⊖			H1	H2	L		C	
		"	mm		"	"	"	mm	"	mm
24GSM-24MPAPI	7341-02735	1 1/2	38.1	1 1/2-11	2	—	5.76	146.3	2.23	56.6
32GSM-32MPAPI	7341-20305	2	50.8	2-11 1/2	2.75	—	9.39	238.5	4.90	124.5

GlobalSpiral™ 缠绕管一体式接头

JIC 37° 内螺纹直接头

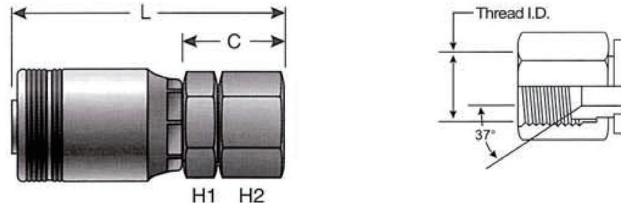

产品描述	编号	⊖		🌀	H1	H2	L		C	
		"	mm		mm	mm	"	mm	"	mm
24GSM-24FJX	7341-02525	1 1/2	38.1	1 7/8-12	55.0	60.0	6.78	172.2	3.04	77.2
32GSM-32FJX	7341-12245	2	50.8	2 1/2-12	70.0	75.0	8.07	205.0	3.59	91.2

JIC 37°内螺纹 45°弯接头

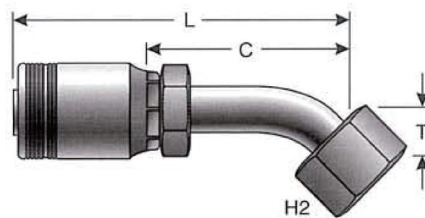

产品描述	编号	⊖		🌀	H1	H1	H2	H2	T		L		C	
		"	mm		"	mm	"	mm	"	mm	"	mm	"	mm
24GSM-24FJX45-034	7341-02535	1 1/2	38.1	1 7/8-12	—	55.0	60.00	—	1.34	34.0	8.90	226.1	5.15	130.8

JIC 37°内螺纹 90°弯接头

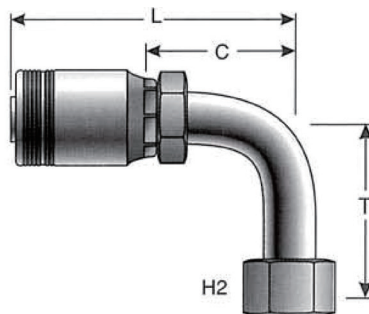

产品描述	编号	⊖		🌀	H1	H1	H2	H2	T		L		C	
		"	mm		"	mm	"	mm	"	mm	"	mm	"	mm
24GSM-24FJX90M	7341-02545	1 1/2	38.1	1 7/8-12	—	55.0	—	60.0	3.39	86.1	8.96	227.1	7.18	182.4

GlobalSpiral™ 缠绕管一体式接头

ORFS 平面密封内螺纹直接头

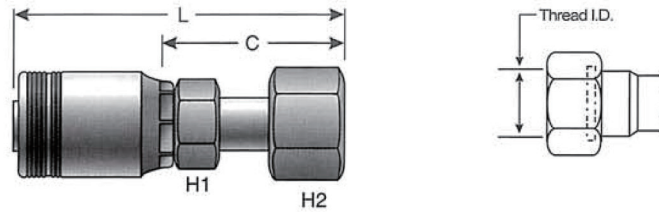

产品描述	编号	⊖			H1	H1	H2	H2	L		C	
		"	mm		"	mm	"	mm	"	mm	"	mm
24GSM-24FFORX	7341-02445	1 1/2	38.1	2-12	2.17	55.0	2.36	60.0	6.47	164.3	2.73	69.3
32GSM3K-32FFORX	7341-20485	2	50.8	2-12	2.76	55.0	2.95	75.0	9.31	236.6	3.11	79.0

ORFS 平面密封内螺纹 45°弯接头

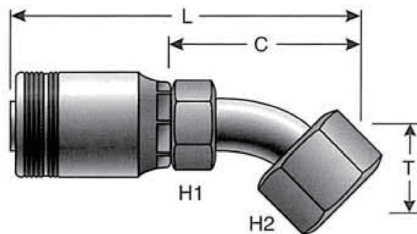

产品描述	编号	⊖			H1	H1	H2	H2	T	L		C		
		"	mm		"	mm	"	mm	"	mm	"	mm	"	mm
24GSM4K-24FFORX45-038	7341-02455	1 1/2	38.1	2-12	2.17	55.0	2.36	60.0	1.50	38.1	9.31	236.6	5.56	141.1

ORFS 平面密封内螺纹 90°弯接头

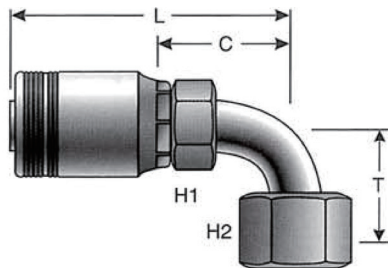

产品描述	编号	⊖			H1	H1	H2	H2	T	L		C		
		"	mm		"	mm	"	mm	"	mm	"	mm	"	mm
24GSM4K-24FFORX90M	7341-02475	1 1/2	38.1	2-12	2.17	55.0	2.36	60.0	3.41	86.6	8.48	215.4	3.69	93.7

GlobalSpiral™ 缠绕管一体式接头

SAE-61 轻型法兰直接头

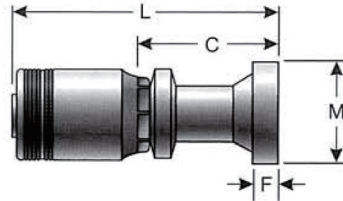

产品描述	编号	⊖		M		L		C		F	
		"	mm	"	mm	"	mm	"	mm	"	mm
24GSM-24FL	7341-01905	1 1/2	38.1	2.38	60.5	7.09	180.1	3.35	85.1	.31	7.9
24GSM-32FL	7341-01915	1 1/2	38.1	2.81	71.4	7.40	188.0	3.66	93.0	.38	9.7
32GSM-32FL	7341-20255	2	50.8	2.81	71.4	9.90	251.5	5.41	137.4	.38	9.7
40GSM-40FL	7341-20905	2 1/2	63.5	3.31	84.1	11.81	300.0	4.80	122.9	.38	9.7

SAE-61 轻型法兰 30°弯接头

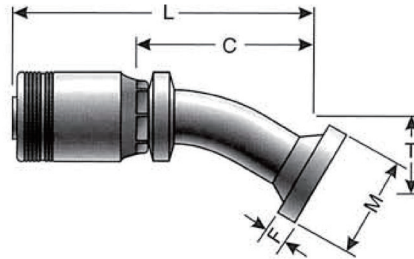

产品描述	编号	⊖		M		T		L		C		F	
		"	mm	"	mm	"	mm	"	mm	"	mm	"	mm
24GSM-24FL30M	7341-01925	1 1/2	38.1	2.38	60.5	1.77	45.0	8.52	216.4	5.00	127.0	.32	8.1

GlobalSpiral™ 缠绕管一体式接头

SAE-61 轻型法兰 45°直接头

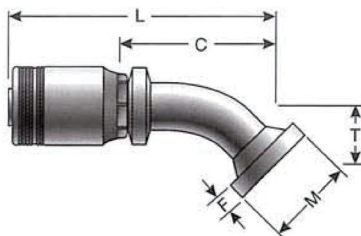

产品描述	编号	⊖		M		T		L		C		F	
		"	mm	"	mm	"	mm	"	mm	"	mm	"	mm
24GSM-24FL45M	7341-01945	1 1/2	38.1	2.38	60.5	1.73	43.9	9.05	229.9	5.31	134.9	.31	7.9
24GSM-32FL45S	7341-01955	1 1/2	38.1	2.81	71.4	2.05	52.1	9.13	231.9	5.34	136.6	.38	9.7
32GSM-32FL45M	7341-20265	2	50.8	2.81	71.4	2.20	55.9	11.30	287.0	6.83	173.5	.38	9.7

SAE-61 轻型法兰 60°弯接头

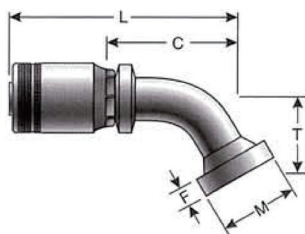

产品描述	编号	⊖		M		T		L		C		F	
		"	mm	"	mm	"	mm	"	mm	"	mm	"	mm
24GSM-24FL60M	7341-01965	1 1/2	38.1	2.38	60.5	2.52	64.0	9.50	241.3	5.75	146.1	.31	7.9

SAE-61 轻型法兰 90°弯接头

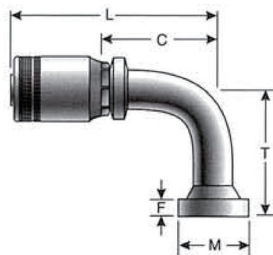

产品描述	编号	⊖		M		T		L		C		F	
		"	mm	"	mm	"	mm	"	mm	"	mm	"	mm
24GSM-24FL90S	7341-01925	1 1/2	38.1	2.38	60.5	3.19	81.0	8.46	214.9	4.72	119.9	.31	7.9
32GSM-32FL90-130	7341-20275	2	50.8	2.81	71.4	5.12	130.1	10.39	263.9	5.94	150.9	.38	9.7

GlobalSpiral™ 缠绕管一体式接头

SAE-62 重型法兰直接头

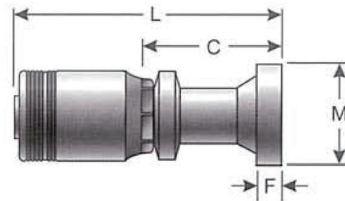

产品描述	编号	⊖		M		L		C		F	
		"	mm	"	mm	"	mm	"	mm	"	mm
24GSM-20FLH	7341-02245	1 1/2	38.1	2.13	54.1	7.87	199.9	4.13	104.9	.41	10.4
24GSM-24FLH	7341-02255	1 1/2	38.1	2.50	63.5	7.87	199.9	4.13	104.9	.50	12.7
24GSM-32FLH	7341-02265	1 1/2	38.1	3.13	79.5	7.87	199.9	4.13	104.9	.50	12.7
32GSM-24FLH	7341-20095	2	50.8	2.50	63.5	9.04	229.6	4.55	115.6	.50	12.7
32GSM-32FLH	7341-20005	2	50.8	3.13	79.5	9.90	251.5	5.41	137.4	.50	12.7

SAE-62 重型法兰 22¹/₂°弯接头

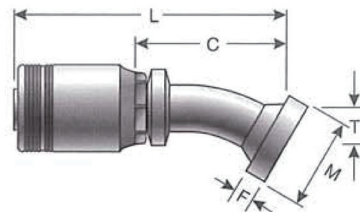

产品描述	编号	⊖		M		T		L		C		F	
		"	mm	"	mm	"	mm	"	mm	"	mm	"	mm
24GSM-24FLH20-024	7341-02395	1 1/2	38.1	2.50	63.5	.94	23.9	9.56	242.8	5.81	147.6	.50	12.7
24GSM-24FLH22M	7341-02275	1 1/2	38.1	2.50	63.5	.70	17.8	9.56	242.8	5.84	148.4	.50	12.7

SAE-62 重型法兰 30°弯接头

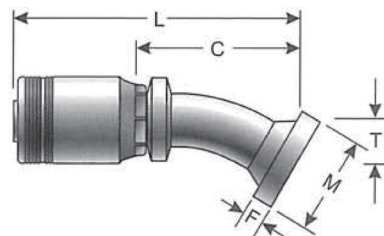

产品描述	编号	⊖		M		T		L		C		F	
		"	mm	"	mm	"	mm	"	mm	"	mm	"	mm
24GSM-24FLH30M	7341-02295	1 1/2	38.1	2.50	63.5	3.54	89.9	9.45	240.0	5.70	144.8	.50	12.7
32GSM-32FLH30M	7341-20065	2	50.8	3.13	79.5	1.25	31.8	12.24	311.0	7.74	196.8	.50	12.7

GlobalSpiral™ 缠绕管一体式接头

SAE-62 重型法兰 45°直接头

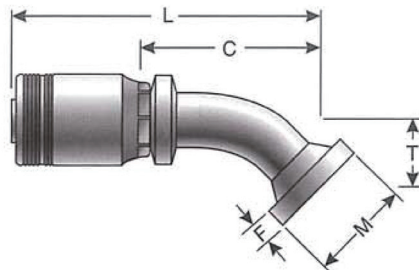

产品描述	编号	⊖		M		T		L		C		F	
		"	mm	"	mm	"	mm	"	mm	"	mm	"	mm
24GSM-24FLH45M	7341-02315	1 1/2	38.1	2.50	63.5	1.73	43.9	9.13	231.9	5.39	136.9	.50	12.7
24GSM-32FLH45M	7341-02325	1 1/2	38.1	3.13	79.5	2.20	55.9	9.48	240.8	5.74	146.0	.50	12.7
32GSM-32FLH45-063	7341-20055	2	50.8	3.13	79.5	2.48	63.0	11.67	296.4	7.18	182.4	.50	12.7

SAE-62 重型法兰 60°弯接头

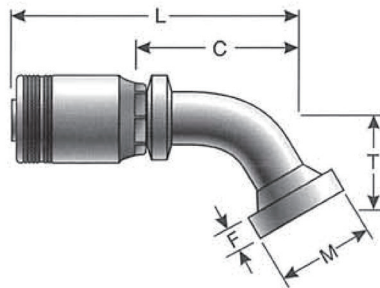

产品描述	编号	⊖		M		T		L		C		F	
		"	mm	"	mm	"	mm	"	mm	"	mm	"	mm
24GSM-24FLH60M	7341-02335	1 1/2	38.1	2.50	63.5	2.50	63.5	9.25	235.0	6.23	158.2	.50	12.7
32GSM-32FLH60M	7341-20075	2	50.8	3.13	79.5	3.26	82.8	12.28	311.9	7.77	197.4	.50	12.7

GlobalSpiral™ 缠绕管一体式接头

SAE-62 重型法兰 90°弯接头

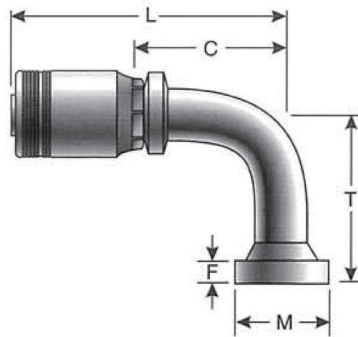

产品描述	编号	⊖		M		T		L		C		F	
		"	mm	"	mm	"	mm	"	mm	"	mm	"	mm
24GSM-24FLH90-094	7341-02355	1 1/2	38.1	2.50	63.5	3.70	94.0	8.73	221.7	4.68	118.9	.50	12.7
24GSM-24FLH90-130	7341-20845	1 1/2	38.1	2.50	63.5	5.12	130.0	8.43	214.0	4.69	119.0	.49	12.6
24GSM-24FLH90-150	7341-02375	1 1/2	38.1	2.50	63.5	5.90	149.9	8.42	213.9	4.68	118.9	.50	12.7
24GSM-32FLH90S	7341-02365	1 1/2	38.1	2.81	71.4	4.72	119.9	8.42	213.9	4.68	118.9	.50	12.7
24GSM-32FLH90-104	7341-02515	1 1/2	38.1	3.13	79.4	4.09	104.0	8.43	214.0	4.68	118.9	.49	12.6
32GSM-32FLH90-159	7341-20035	2	50.8	3.13	79.5	6.26	159.0	10.41	264.4	5.92	150.4	.50	12.7
32GSM-32FLH90-170	7341-20835	2	50.8	3.13	79.4	6.69	170.0	10.39	264.0	5.90	150.4	.49	12.6
32GSM-32FLH90M	7341-20045	2	50.8	3.13	79.5	5.40	137.2	10.41	264.4	6.24	158.5	.50	12.7
32GSM-32FLH90S	7341-20085	2	50.8	3.13	79.5	4.72	119.9	10.39	263.9	5.92	150.4	.50	12.7

BSP 直管内螺纹 60°锥带 O 型圈直接头

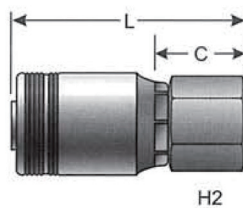

产品描述	编号	⊖		🌀	H1	H2	L		C	
		"	mm		mm	mm	"	mm	"	mm
24GSM-24FBSPORX	7341-07015	1 1/2	38.1	1 1/2	—	55.0	6.06	153.9	2.32	58.9
24GSM-32FBSPORX	7341-20555	2	50.8	2-11	—	70.0	7.24	183.9	2.75	69.9

GlobalSpiral™ 缠绕管一体式接头

BSP 直管内螺纹 60°锥带 O 型圈 45°弯接头

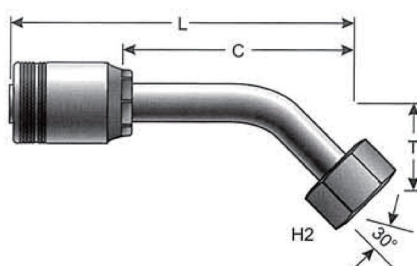

产品描述	编号	⊖			H1	H2	T		L		C	
		"	mm		mm	mm	"	mm	"	mm	"	mm
24GSM-24FBSPORX45	7341-07035	1 1/2	38.1	1 1/2	—	55.0	1.96	49.8	9.56	242.8	5.81	147.6
32GSM-32FBSPORX45	7341-20565	2	50.8	2-11	—	70.0	3.40	86.4	12.56	319.0	8.06	204.7

BSP 直管内螺纹 60°锥带 O 型圈 90°弯接头

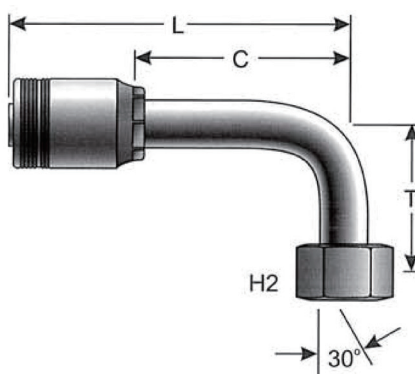

产品描述	编号	⊖			H1	H2	T		L		C	
		"	mm		mm	mm	"	mm	"	mm	"	mm
24GSM-24FBSPORX90	7341-07045	1 1/2	38.1	1 1/2	—	55.0	3.94	100.1	8.76	222.5	5.02	127.5
32GSM-32FBSPORX90	7341-20575	2	50.8	2-11	—	70.0	6.54	166.1	10.89	276.6	6.39	162.3

MegaCrimp™ 编织管一体式接头

公制 24°锥外螺纹轻系列直接头

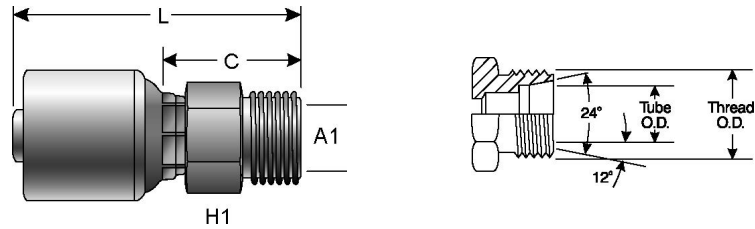

产品描述	编号	⊖		🌀	H1	H2	L		C		A1
		"	mm				"	mm	"	mm	
4G-6MDL	7100-92685	1/4	6.4	M12X1.5	14.0	-	1.69	42.9	.78	19.8	6.0
4G-8MDL	7100-14835	1/4	6.4	M14X1.5	17.0	-	1.97	50.0	.94	24.0	8.0
4G-10MDL	7100-14845	1/4	6.4	M18X1.5	17.0	-	2.01	51.0	.98	25.0	10.0
6G-10MDL	7100-14865	3/8	9.5	M16X1.5	17.0	-	2.07	52.5	.97	24.6	10.0
6G-12MDL	7100-14875	3/8	9.5	M18X1.5	19.0	-	2.07	52.5	.97	24.6	12.0
6G-15MDL	7100-92695	3/8	9.5	M22X1.5	24.0	-	1.86	47.3	.94	23.9	15.0
8G-15MDL	7100-04885	1/2	12.7	M22X1.5	24.0	-	2.56	65.0	1.08	27.5	15.0
10G-18MDL	7100-04895	5/8	15.9	M26X1.5	27.0	-	2.56	65.0	1.08	27.5	18.0
10G-22MDL	7100-04935	5/8	15.9	M30X2.0	32.0	-	2.75	69.8	1.27	32.3	22.0
12G-22MDL	7100-04905	3/4	19.1	M30X2.0	32.0	-	3.27	83.0	1.26	32.0	22.0
16G-28MDL	7100-04915	1	25.4	M36X2.0	41.0	-	3.70	94.0	1.46	37.2	28.0
20G-35MDL	7100-04925	1 1/4	31.8	M45X2.0	46.0	-	3.92	99.5	1.59	40.5	35.0

公制 24°锥内螺纹带 O 型圈轻系列直接头

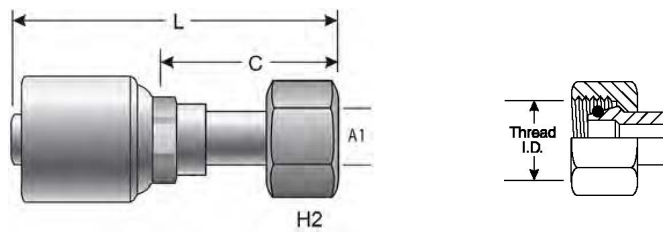

产品描述	编号	⊖		🌀	H1	H2	L		C		A1
		"	mm				"	mm	"	mm	
4G-6FDLORX	7100-95665	1/4	6.4	M12X1.5	-	14.0	1.99	50.5	0.96	24.5	6.0
4G-8FDLORX	7100-95685	1/4	6.4	M14X1.5	-	17.0	2.07	52.5	1.04	26.5	8.0
4G-10FDLORX	7100-95705	1/4	6.4	M16X1.5	-	19.0	2.11	53.5	1.08	27.5	10.0
4G-12FDLORX	7100-92865	1/4	6.4	M18X1.5	-	22.0	2.07	52.6	1.17	29.7	12.0
5G-10FDLORX	7100-92015	5/16	7.9	M16X1.5	-	19.0	2.12	53.9	1.17	29.7	10.0
5G-12FDLORX	7100-92035	5/16	7.9	M18X1.5	-	22.0	2.30	58.5	1.18	30.0	12.0
6G-10FDLORX	7100-96065	3/8	9.5	M16X1.5	-	19.0	2.17	55.0	1.07	27.1	10.0
6G-12FDLORX	7100-96085	3/8	9.5	M18X1.5	-	22.0	2.19	55.5	1.09	27.6	12.0
8G-15FDLORX	7100-25445	1/2	12.7	M22X1.5	-	27.0	2.50	63.5	1.02	26.0	15.0
10G-18FDLORX	7100-92095	5/8	15.9	M26X1.5	-	32.0	2.36	60.0	1.19	30.3	18.0
12G-18FDLORX	7100-92825	3/4	19.1	M26X1.5	-	32.0	2.70	68.5	1.18	30.0	18.0
12G-22FDLORX	7100-92115	3/4	19.1	M30X2.0	-	36.0	2.79	70.8	1.27	32.3	22.0
16G-28FDLORX	7100-92205	1	25.4	M36X2.0	-	41.0	3.21	81.6	1.45	36.7	28.0
20G-35FDLORX	7100-92215	1 1/4	31.8	M45X2.0	-	-	3.56	90.4	1.74	44.1	35.0
20G-42FDLORX	7100-95305	1 1/4	31.8	M52X2.0	-	60.0	4.25	108.0	1.93	49.0	42.0

MegaCrimp™ 编织管一体式接头

公制 24°锥内螺纹带 O 型圈轻系列 45°弯接头

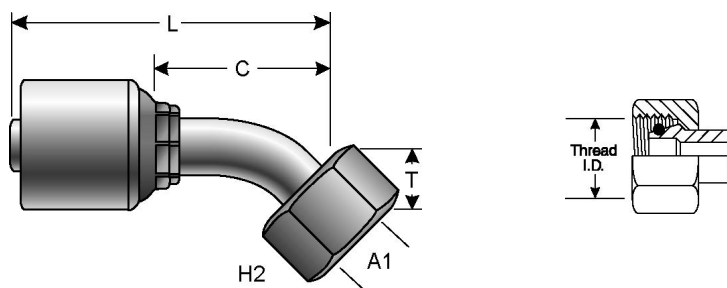

产品描述	编号	⊘		🌀	H1	H2	T		L		C		A1
		"	mm		mm	mm	"	mm	"	mm	"	mm	mm
4G-8FDLORX45	7100-95755	1/4	6.4	M14X1.5	-	17.0	.64	16.2	2.56	65.1	1.54	39.0	8.0
4G-10FDLORX45	7100-95775	1/4	6.4	M16X1.5	-	19.0	.70	17.9	2.63	66.9	1.61	40.8	10.0
5G-10FDLORX45	7100-91895	5/16	7.9	M16X1.5	-	19.0	.67	17.1	2.50	63.4	1.55	39.3	10.0
6G-10FDLORX45	7100-92295	3/8	9.5	M16X1.5	-	19.0	.73	18.6	2.50	63.6	1.59	40.5	10.0
6G-12FDLORX45	7100-96155	3/8	9.5	M18X1.5	-	22.0	.74	18.9	2.71	68.8	1.61	40.9	12.0
6G-15FDLORX45	7100-92315	3/8	9.5	M22X1.5	-	27.0	.89	22.5	2.66	67.5	1.75	44.4	15.0
8G-15FDLORX45	7100-96475	1/2	12.7	M22X1.5	-	27.0	.79	20.2	3.32	84.4	1.85	47.0	15.0
10G-18FDLORX45	7100-91955	5/8	15.9	M26X1.5	-	32.0	.98	24.8	3.37	85.7	2.21	56.0	18.0
12G-22FDLORX45	7100-91975	3/4	19.1	M30X2.0	-	36.0	1.17	29.8	4.12	104.6	2.60	66.1	22.0
16G-28FDLORX45	7100-92325	1	25.4	M36X2.0	-	41.0	1.21	30.9	4.87	123.7	3.10	78.8	28.0
20G-35FDLORX45	7100-92335	1 1/4	31.8	M45X2.0	-	50.0	1.48	37.5	5.48	139.3	3.68	93.4	35.0

公制 24°锥内螺纹带 O 型圈轻系列 90°弯接头

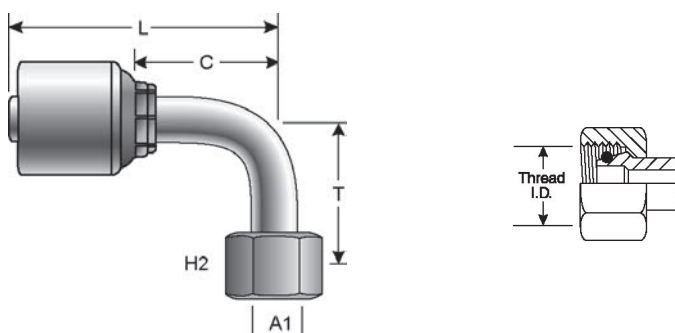

产品描述	编号	⊘		🌀	H1	H2	T		L		C		A1
		"	mm		mm	mm	"	mm	"	mm	"	mm	mm
4G-6FDLORX90	7100-92375	1/4	6.4	M12X1.5	-	14.0	1.38	35.0	2.15	54.5	1.24	31.5	6.0
4G-8FDLORX90	7100-95845	1/4	6.4	M14X1.5	-	17.0	1.38	35.0	2.36	60.0	1.34	34.0	8.0
4G-10FDLORX90	7100-95865	1/4	6.4	M16X1.5	-	19.0	1.44	36.5	2.36	60.0	1.34	34.0	10.0
5G-10FDLORX90	7100-91725	5/16	7.9	M16X1.5	-	19.0	1.44	36.5	2.31	58.6	1.35	34.4	10.0
6G-10FDLORX90	7100-96195	3/8	9.5	M16X1.5	-	19.0	1.44	37.0	2.37	60.1	1.27	32.2	10.0
6G-12FDLORX90	7100-96215	3/8	9.5	M18X1.5	-	22.0	1.46	37.0	2.37	60.1	1.27	32.2	12.0
8G-15FDLORX90	7100-96505	1/2	12.7	M22X1.5	-	27.0	1.65	42.0	3.06	77.8	1.59	40.3	15.0
10G-18FDLORX90	7100-91785	5/8	15.9	M26X1.5	-	32.0	2.03	51.5	3.04	77.3	1.87	47.6	18.0
12G-22FDLORX90	7100-91805	3/4	19.1	M30X2.0	-	36.0	2.44	62.0	3.73	94.8	2.22	56.3	22.0
16G-28FDLORX90	7100-92445	1	25.4	M36X2.0	-	41.0	2.76	70.0	4.69	119.2	2.93	74.3	28.0
20G-35FDLORX90	7100-92455	1 1/4	31.8	M45X2.0	-	50.0	3.15	80.0	5.07	128.8	3.26	82.8	35.0

MegaCrimp™ 编织管一体式接头

公制 24°锥外螺纹重系列直接头

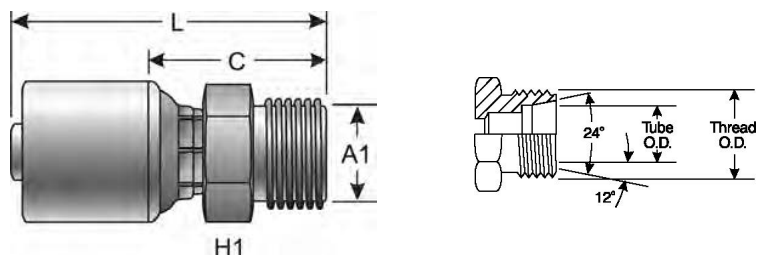

产品描述	编号	⌀		🌀	H1	H2	L		C		A1
		"	mm		mm	mm	mm	"	mm	"	mm
4G-8MDH	7100-15315	1/4	6.4	M16X1.5	17.0	-	2.09	53.0	1.06	27.0	8.0
4G-10MDH	7100-15325	1/4	6.4	M18X1.5	19.0	-	2.07	52.5	1.04	26.5	10.0
5G-12MDH	7100-93015	5/16	7.9	M20X1.5	22.0	-	2.04	51.9	1.09	27.8	12.0
6G-10MDH	7100-15345	3/8	9.5	M18X1.5	19.0	-	2.17	55.0	1.07	27.1	10.0
6G-12MDH	7100-15355	3/8	9.5	M20X1.5	24.0	-	2.26	57.5	1.17	29.6	12.0
6G-14MDH	7100-15365	3/8	9.5	M22X1.5	24.0	-	2.34	59.5	1.24	31.6	14.0
8G-12MDH	7100-94815	1/2	12.7	M20X1.5	24.0	-	2.42	61.5	1.14	29.0	12.0
8G-16MDH	7100-05375	1/8	12.7	M24X1.5	27.0	-	2.72	69.0	1.24	31.5	16.0
10G-20MDH	7100-05385	5/8	15.9	M30X2.0	32.0	-	2.89	73.5	1.42	36.0	20.0
12G-20MDH	7100-92755	3/4	19.1	M30X2.0	32.0	-	2.85	72.3	1.33	33.9	20.0
12G-25MDH	7100-05395	3/4	19.1	M36X2.0	41.0	-	3.62	92.0	1.61	41.0	25.0
16G-30MDH	7100-92535	1	25.4	M42X2.0	46.0	-	3.48	88.3	1.67	42.4	30.0
20G-38MDH	7100-92545	1 1/4	31.8	M52X2.0	55.0	-	3.72	94.4	1.93	49.1	38.0

公制 24°锥内螺纹带 O 型圈重系列直接头

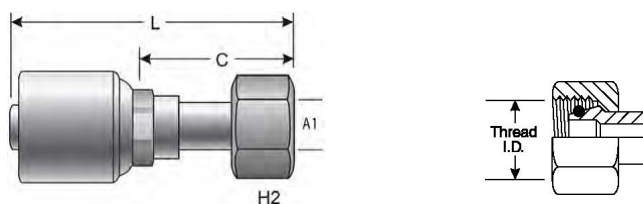

产品描述	编号	⌀		🌀	H1	H2	L		C		A1
		"	mm		mm	mm	mm	"	mm	"	mm
4G-8FDHORX	7100-95675	1/4	6.4	M16X1.5	-	19.0	2.06	52.5	1.04	26.5	8.0
4G-10FDHORX	7100-95695	1/4	6.4	M18X1.5	-	22.0	2.10	53.5	1.08	27.5	10.0
4G-12FDHORX	7100-25405	1/4	6.4	M20X1.5	-	24.0	2.06	52.5	1.04	26.5	12.0
5G-12FDHORX	7100-92045	5/16	7.9	M20X1.5	-	24.0	2.28	58.0	1.18	30.0	12.0
5G-14FDHORX	7100-94835	5/16	7.9	M22X1.5	-	27.0	2.11	53.6	1.18	30.0	14.0
6G-10FDHORX	7100-96055	3/8	9.5	M18X1.5	-	22.0	2.16	55.0	1.06	27.1	10.0
6G-12FDHORX	7100-96075	3/8	9.5	M20X1.5	-	24.0	2.18	55.5	1.08	27.6	12.0
6G-14FDHORX	7100-96095	3/8	9.5	M22X1.5	-	27.0	2.18	58.0	1.08	30.1	14.0
8G-12FDHORX	7100-93335	1/2	12.7	M20X1.5	-	24.0	2.76	70.2	1.29	32.7	12.0
8G-14FDHORX	7100-96415	1/2	12.7	M22X1.5	-	27.0	2.72	68.0	1.24	30.5	14.0
8G-16FDHORX	7100-96435	1/2	12.7	M24X1.5	-	30.0	2.72	69.0	1.24	31.5	16.0
10G-20FDHORX	7100-92105	5/8	15.9	M30X2.0	-	36.0	2.67	67.9	1.51	38.2	20.0
12G-20FDHORX	7100-96675	3/4	19.1	M30X2.0	-	36.0	3.61	91.7	1.60	40.7	20.0
12G-25FDHORX	7100-92125	3/4	19.1	M36X2.0	-	46.0	3.19	81.1	1.68	42.6	25.0
16G-25FDHORX	7100-93215	1	25.4	M36X2.0	-	46.0	4.04	102.5	1.80	45.7	25.0
16G-30FDHORX	7100-92235	1	25.4	M42X2.0	-	50.0	3.70	94.1	1.94	49.2	30.0
20G-38FDHORX	7100-92245	1 1/4	31.8	M52X2.0	-	60.0	4.10	104.1	2.28	57.8	38.0

MegaCrimp™ 编织管一体式接头

公制 24°锥内螺纹带 O 型圈重系列 45°弯接头

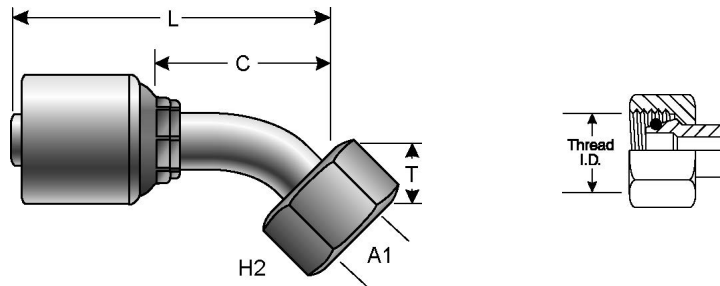

产品描述	编号	⊖		🌀	H1	H2	T		L		C		A1
		"	mm		mm	mm	"	mm	"	mm	"	mm	mm
4G-8FDHORX45	7100-91865	1/4	6.4	MX16X1.5	-	19.0	.64	16.2	2.34	59.5	1.44	36.5	8.0
4G-10FDHORX45	7100-95765	1/4	6.4	MX18X1.5	-	22.0	.70	17.9	2.54	64.4	1.51	38.3	7.9
6G-10FDHORX45	7100-96125	3/8	9.5	MX18X1.5	-	22.0	.73	18.6	2.70	68.5	1.59	40.5	10.9
6G-12FDHORX45	7100-96145	3/8	9.5	MX20X1.5	-	24.0	.74	18.9	2.71	68.8	1.61	40.9	12.0
8G-14FDHORX45	7100-94855	1/2	12.7	MX22X1.5	-	27.0	1.11	28.3	3.40	86.4	2.13	54.0	14.0
8G-16FDHORX45	7100-96485	1/2	12.7	MX24X1.5	-	30.0	.85	21.6	3.38	85.9	1.91	48.4	16.0
10G-20FDHORX45	7100-91965	5/8	15.9	MX30X2.0	-	36.0	.98	24.9	3.36	85.4	2.19	55.7	20.0
12G-25FDHORX45	7100-91985	3/4	19.1	MX36X2.0	-	46.0	1.23	31.2	4.17	106.0	2.66	67.6	25.0
12G-20FDHORX45	7100-9490	3/4	19.1	MX30X2.0	-	36.0	.98	24.9	4.31	109.4	2.30	58.4	20
16G-25FDHORX45	7100-9491	1	25.4	MX36X2.0	-	46.0	1.38	35.1	5.77	146.5	3.53	89.7	25

公制 24°锥内螺纹带 O 型圈重系列 90°弯接头

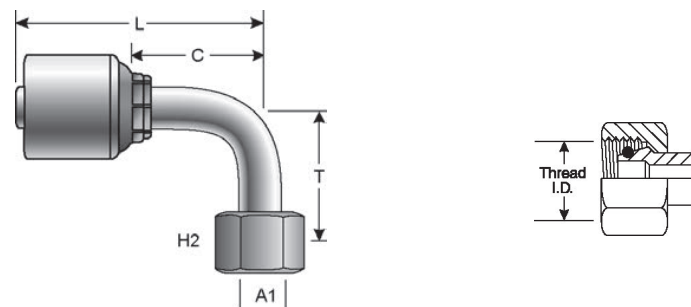

产品描述	编号	⊖		🌀	H1	H2	T		L		C		A1
		"	mm		mm	mm	"	mm	"	mm	"	mm	mm
4G-8FDHORX90	7100-95835	1/4	6.4	M16X1.5	-	19.0	1.38	35.0	2.36	60.0	1.34	34.0	8.0
4G-10FDHORX90	7100-95855	1/4	6.4	M18X1.5	-	22.0	1.44	36.5	2.36	60.0	1.34	34.0	10.0
5G-12FDHORX90	7100-91755	5/16	7.9	M20X1.5	-	24.0	1.46	37.0	2.32	59.0	1.22	31.0	12.0
5G-14FDHORX90	7100-94845	5/16	7.9	M22X1.5	-	27.0	1.57	40.0	2.15	54.6	1.22	31.0	14.0
6G-10FDHORX90	7100-92425	3/8	9.5	M18X1.5	-	22.0	1.44	36.5	2.18	55.3	1.27	32.2	10.0
6G-12FDHORX90	7100-96205	3/8	9.5	M20X1.5	-	24.0	1.46	37.0	2.36	60.1	1.27	32.2	12.0
6G-14FDHORX90	7100-92465	3/8	9.5	M22X1.5	-	27.0	1.57	40.0	2.18	55.3	1.27	32.2	14.0
8G-14FDHORX90	7100-13005	1/2	12.7	M22X1.5	-	27.0	2.01	51.0	3.11	79.0	1.64	41.6	14.0
8G-16FDHORX90	7100-96515	1/2	12.7	M24X1.5	-	30.0	1.73	44.0	3.06	77.8	1.59	40.3	16.0
10G-20FDHORX90	7100-91795	5/8	15.9	M30X2.0	-	36.0	2.01	51.0	3.00	76.3	1.83	46.6	20.0
10G-25FDHORX90	7100-94825	5/8	15.9	M36X2.0	-	46.0	2.52	64.0	3.31	84.1	1.83	46.6	25.0
12G-20FDHORX90	7100-93035	3/4	19.1	M30X2.0	-	36.0	2.01	51.0	3.46	87.8	1.94	49.3	20.0
12G-25FDHORX90	7100-91815	3/4	19.1	M36X2.0	-	46.0	2.52	64.0	3.73	94.8	2.22	56.3	25.0
16G-25FDHORX90	7100-94925	1	25.4	M36X2.0	-	46.0	2.99	76.0	5.43	137.8	3.19	81.0	25.0
16G-30FDHORX90	7100-9247	1	25.4	MX42X2.0	-	50.0	2.99	76.0	4.69	119.15	2.93	74.3	30
20G-38FDHORX90	7100-9493	1 1/4	31.8	MX52X2.0	-	60.0	3.43	87.0	5.96	151.4	3.64	92.4	38

MegaCrimp™ 编织管一体式接头

NPTF 锥管外螺纹接头直接头

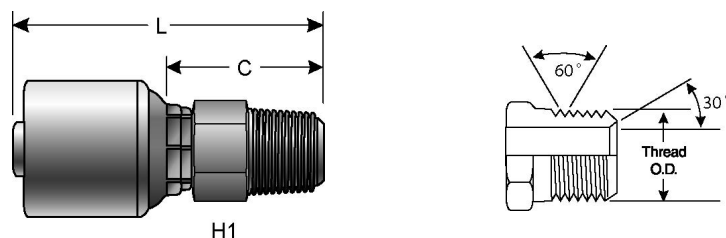

产品描述	编号	⊖		🌀	H1	H2	L		C	
		"	mm				"	mm	"	mm
4G-2MP	7100-10025	1/4	6.4	1/8-27	1/2	-	1.96	49.8	.94	23.9
4G-4MP	7100-10035	1/4	6.4	1/4-18	9-16	-	2.17	55.0	1.14	29.0
4G-6MP	7100-10045	1/4	6.4	3/8-18	11/16	-	2.17	55.0	1.14	29.0
4G-8MP	7100-10055	1/4	6.4	1/2-14	7/8	-	2.44	62.0	1.41	35.8
5G-4MP	7100-00065	5/16	7.9	1/4-18	5/8	-	2.28	58.0	1.18	30.0
5G-6MP	7100-10065	5/16	7.9	3/8-18	11/16	-	2.32	59.0	1.22	31.0
6G-4MP	7100-10075	3/8	9.5	1/4-18	7/8	-	2.32	58.9	1.22	31.0
6G-6MP	7100-10085	3/8	9.5	3/8-18	13/16	-	2.32	58.9	1.22	31.0
6G-8MP	7100-10095	3/8	9.5	1/2-14	7/8	-	2.51	63.8	1.42	36.1
8G-4MP	7100-10105	1/2	12.7	1/4-18	13/16	-	2.72	69.0	1.24	31.5
8G-6MP	7100-00105	1/2	12.7	3/8-18	13/16	-	2.72	69.0	1.24	31.5
8G-8MP	7100-00115	1/2	12.7	1/2-14	7/8	-	2.87	73.0	1.40	35.5
8G-12MP	7100-00125	1/2	12.7	3/4-14	1 1/16	-	2.95	74.9	1.47	37.3
10G-8MP	7100-00225	5/8	15.9	1/2-14	15/16	-	2.95	75.0	1.48	37.5
10G-12MP	7100-00235	5/8	15.9	3/4-14	1 1/16	-	2.95	75.0	1.48	37.5
12G-8MP	7100-00155	3/4	19.1	1/2-14	1 1/16	-	3.46	87.9	1.45	36.8
12G-12MP	7100-00165	3/4	19.1	3/4-14	1 1/16	-	3.46	87.9	1.45	36.8
12G-16MP	7100-00175	3/4	19.1	1 1/11 1/2	1 3/8	-	3.77	95.8	1.77	45.0
16G-12MP	7100-00195	1	25.4	3/4-14	1 3/8	-	3.93	99.8	1.70	43.2
16G-16MP	7100-00205	1	25.4	1-11 1/2	1 3/8	-	4.11	104.4	1.87	47.5
20G-20MP	7100-00215	1 1/4	31.8	1 1/4-11 1/2	1 3/4	-	4.44	112.8	2.12	53.8

NPTF 锥管外螺纹加长型直接头

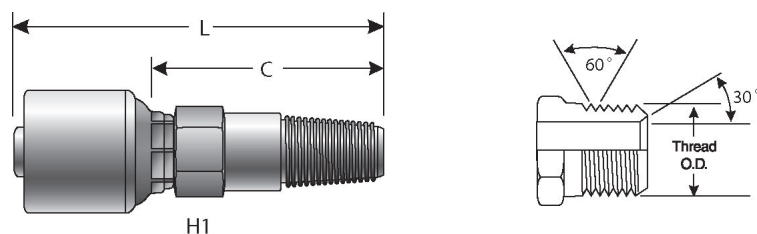

产品描述	编号	⊖		🌀	H1	H2	L		C	
		"	mm				"	mm	"	mm
4G-4MPLN	7100-16615	1/4	6.4	1/4-18	9/16	-	2.56	65.0	1.54	39.0
4G-6MPLN	7100-16625	1/4	6.4	3/8-18	11/16	-	2.56	65.0	1.54	39.0
6G-4MPLN	7100-16645	3/8	9.5	1/4-18	5/8	-	2.72	69.0	1.62	41.1
6G-6MPLN	7100-16635	3/8	9.5	3/8-18	11/16	-	2.72	69.0	1.62	41.1

MegaCrimp™ 编织管一体式接头

NPTF 锥管外螺纹可旋转直接头

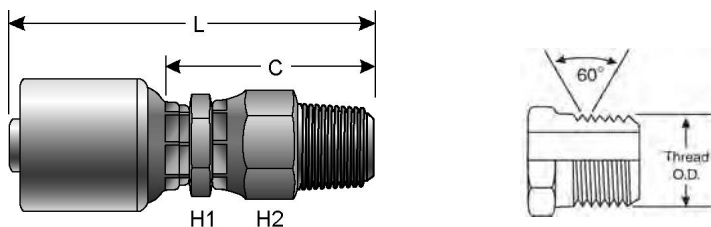

产品描述	编号	⊖		🌀	H1	H2	L		C	
		"	mm				"	mm	"	mm
4G-2MPX	7100-10245	1/4	6.4	1/8-27	1/2	1/2	2.39	60.7	1.37	34.8
4G-4MPX	7100-10255	1/4	6.4	1/4-18	1/2	11/16	2.61	66.3	1.58	40.1
4G-6MPX	7100-10265	1/4	6.4	3/8-18	5/8	7/8	2.73	69.3	1.71	43.4
4G-8MPX	7100-10275	1/4	6.4	1/2-14	3/4	1	2.97	75.4	1.94	49.4
6G-4MPX	7100-10285	3/8	9.5	1/4-18	5/8	7/8	2.87	72.8	1.77	44.9
6G-6MPX	7100-10295	3/8	9.5	3/8-18	5/8	7/8	2.81	71.4	1.71	43.4
6G-8MPX	7100-10305	3/8	9.5	1/2-14	3/4	1	3.04	77.2	1.94	49.3
8G-6MPX	7100-00315	1/2	12.7	3/8-18	13/16	7/8	3.22	81.8	1.75	44.5
8G-8MPX	7100-00325	1/2	12.7	1/2-14	13/16	1	3.42	86.9	1.94	49.3
10G-12MPX	7100-00335	5/8	15.9	3/4-14	1 1/16	1 5/16	3.48	88.4	1.75	51.1
12G-8MPX	7100-00345	3/4	19.1	1/2-14	1 1/16	1	3.97	100.8	1.94	49.8
12G-12MPX	7100-00355	3/4	19.1	3/4-14	1 1/16	1 5/16	4.01	101.9	2.01	50.8
16G-16MPX	7100-00365	1	25.4	1-11 1/2	1 3/8	1 5/8	4.73	120.1	1.96	63.2

NPTF 锥管外螺纹可旋转 90°弯接头

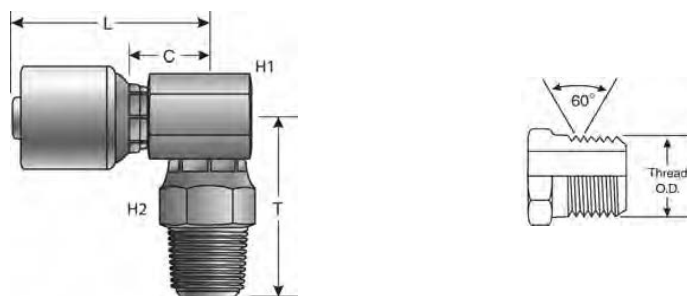

产品描述	编号	⊖		🌀	H1	H2	T		L		C	
		"	mm				"	mm	"	mm	"	mm
4G-2MPX90	7100-10365	1/4	6.4	1/8-27	11/16	1/2	1.20	30.5	1.75	44.4	.72	18.3
4G-4MPX90	7100-10375	1/4	6.4	1/4-18	11/16	11/16	1.62	41.1	1.75	44.5	.72	18.3
4G-6MPX90	7100-10385	1/4	6.4	3/8-18	11/16	7/8	1.73	43.9	1.82	46.2	.79	20.1
6G-4MPX90	7100-10395	3/8	9.5	1/4-18	3/4	11/16	1.65	41.9	1.96	49.7	.85	21.6
6G-6MPX90	7100-10405	3/8	9.5	3/8-18	3/4	7/8	1.76	44.7	1.96	49.7	.85	21.6
6G-8MPX90	7100-10415	3/8	9.5	1/2-14	3/4	1	1.93	49.1	1.96	49.7	.85	21.6
8G-6MPX90	7100-07135	1/2	12.7	3/8-18	-	7/8	1.88	47.8	2.55	64.7	1.07	27.2
8G-8MPX90	7100-00425	1/2	12.7	1/2-14	-	1	2.05	52.1	2.55	64.7	1.07	27.2
12G-12MPX90	7100-00435	3/4	19.1	3/4-14	-	1 5/16	2.30	58.4	3.17	80.5	1.16	29.5

MegaCrimp™ 编织管一体式接头

NPTF 锥管内螺纹直接头

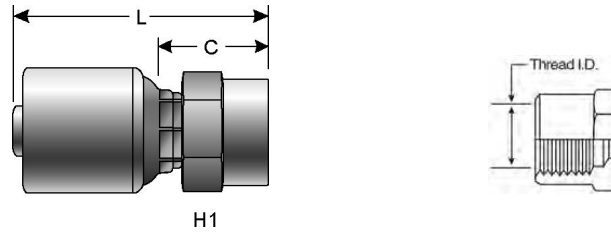

产品描述	编号	⊖		🌀	H1		L		C	
		"	mm		"	"	"	mm	"	mm
4G-2FP	7100-10485	1/4	6.4	1/8-27	9/16	-	1.74	44.2	.72	18.3
4G-4FP	7100-10495	1/4	6.4	1/4-18	11/16	-	1.98	50.3	.96	24.4
4G-6FP	7100-10505	1/4	6.4	3/8-18	13/16	-	1.98	50.3	.96	24.4
6G-4FP	7100-10515	3/8	9.5	1/4-18	11/16	-	2.00	50.8	.90	22.9
6G-6FP	7100-10525	3/8	9.5	3/8-18	13/16	-	2.06	52.3	.96	24.4
6G-8FP	7100-10535	3/8	9.5	1/2-14	1	-	2.24	56.9	1.14	29.0
8G-6FP	7100-00545	1/2	12.7	3/8-18	13/16	-	2.46	62.5	.98	24.9
8G-8FP	7100-00555	1/2	12.7	1/2-14	1	-	2.63	66.8	1.16	29.5
12G-12FP	7100-00565	3/4	19.1	3/4-14	1 1/4	-	3.22	81.8	1.22	31.0

NPSM 锥管内螺纹可旋转带 30°锥座直接头

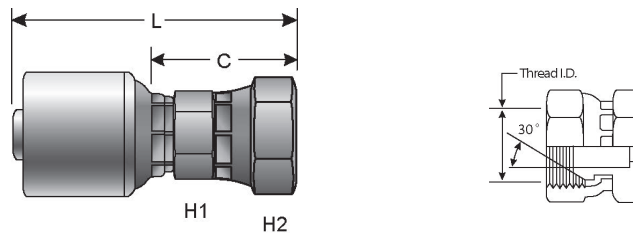

产品描述	编号	⊖		🌀	H1		H2		L		C	
		"	mm		"	mm	"	mm	"	mm	"	mm
4G-4FPX	7100-10575	1/4	6.4	1/4-18	1/2	-	11/16	-	2.24	56.9	1.21	30.7
6G-6FPX	7100-10585	3/8	9.5	3/8-18	5/8	-	7/8	-	2.48	63.0	1.38	35.1
6G-8FPX	7100-10595	3/8	9.5	1/2-14	13/16	-	1	-	2.55	64.8	1.45	36.8
8G-8FPX	7100-00595	1/2	12.7	1/2-14	13/16	-	1	-	2.88	73.2	1.41	35.8
12G-12FPX	7100-00605	3/4	19.1	3/4-14	-	27.0	1 1/4	-	3.71	94.2	1.70	43.2
16G-16FPX	7100-00615	1	25.4	1-11 1/2	1 3/8	-	1 1/2	-	4.10	104.1	1.87	47.5
20G-20FPX	7100-00625	1 1/4	31.8	1 1/4-11 1/2	1 3/4	-	1 7/8	-	4.67	118.6	2.26	57.4

MegaCrimp™ 编织管一体式接头

SAE 直管外螺纹带 O 型圈密封直接头

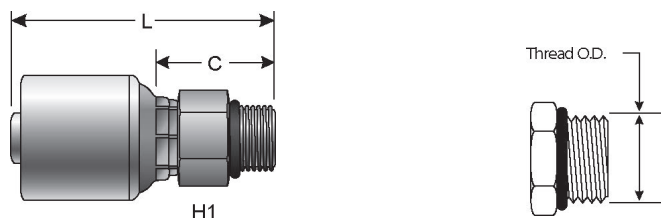

产品描述	编号	⊖		🌀	H1		H2		L		C	
		"	mm		"	mm	"	mm	"	mm	"	mm
4G-4MB	7100-12205	1/4	6.4	7/16-20	9/16	-	-	-	1.99	50.5	0.96	24.5
4G-5MB	7100-12215	1/4	6.4	1/2-20	5/8	-	-	-	1.99	50.5	0.96	24.5
4G-6MB	7100-12225	1/4	6.4	9/16-18	11/16	-	-	-	2.05	52.1	1.02	26.0
6G-5MB	7100-12285	3/8	9.5	1/2-20	5/8	-	-	-	2.05	52.1	0.95	24.1
6G-6MB	7100-13235	3/8	9.5	9/16-18	11/16	-	-	-	2.20	55.9	1.11	28.1
6G-8MB	7100-13245	3/8	9.5	3/4-16	7/8	-	-	-	2.28	57.9	1.19	30.1
6G-10MB	7100-12255	3/8	9.5	7/8-14	1	-	-	-	2.22	56.4	1.13	28.6
6G-12MB	7100-12265	3/8	9.5	1 1/16-12	1 1/4	-	-	-	2.42	61.5	1.32	33.6
8G-8MB	7100-13275	1/2	12.7	3/4-16	7/8	-	-	-	2.64	67.1	1.16	29.5
8G-10MB	7100-13285	1/2	12.7	7/8-14	1	-	-	-	2.68	68.1	1.20	30.5
8G-12MB	7100-13295	1/2	12.7	1 1/16-12	1 1/4	-	-	-	2.91	73.9	1.44	36.5
10G-8MB	7100-02305	5/8	15.9	3/4-16	15/16	-	-	-	2.83	71.9	1.36	34.5
10G-10MB	7100-13315	5/8	15.9	7/8-14	1	-	-	-	2.83	71.9	1.36	34.5
10G-12MB	7100-13325	5/8	15.9	1 1/16-12	1 1/4	-	-	-	2.99	75.9	1.52	38.5
12G-10MB	7100-02265	3/4	19.1	7/8-14	1	-	-	-	3.23	82.0	1.22	31.1
12G-12MB	7100-02335	3/4	19.1	1 1/16-12	1 1/4	-	-	-	3.33	84.6	1.32	33.5
12G-14MB	7100-02345	3/4	19.1	1 3/16-12	1 3/8	-	-	-	3.31	84.1	1.30	33.0
12G-16MB	7100-02355	3/4	19.1	1 5/16-12	1 1/2	-	-	-	3.44	87.4	1.44	36.5
16G-14MB	7100-02365	1	25.4	1 3/16-12	1 3/8	-	-	-	3.78	96.0	1.54	39.2
16G-16MB	7100-02375	1	25.4	1 5/16-12	1 1/2	-	-	-	3.84	97.5	1.60	40.7
16G-20MB	7100-02255	1	25.4	1 5/8-12	1 7/8	-	-	-	3.74	95.0	1.50	38.2

SAE 直管外螺纹可旋转带 O 型圈密封直接头

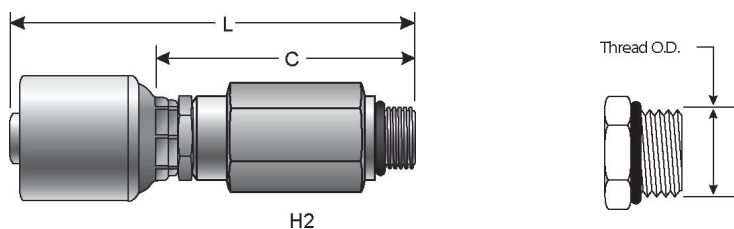

产品描述	编号	⊖		🌀	H1	H2	L		C	
		"	mm		mm	mm	"	mm	"	mm
4G-4MBX	7209-40015	1/4	6.4	7/16-20	-	19.0	3.21	81.5	2.19	55.5
4G-6MBX	7209-40025	1/4	6.4	9/16-18	-	19.0	3.21	81.5	2.19	55.5
6G-6MBX	7209-40045	3/8	9.5	9/16-18	-	22.0	3.33	84.5	2.23	56.6
6G-8MBX	7209-40055	3/8	9.5	3/4-16	-	23.0	3.33	84.5	2.23	56.6
6G-10MBX	7209-40065	3/8	9.5	7/8-14	-	27.0	3.21	81.5	2.11	53.6
8G-8MBX	7209-40085	1/2	12.7	3/4-16	-	23.0	3.78	96.0	2.30	58.5
8G-10MBX	7209-40095	1/2	12.7	7/8-14	-	27.0	3.84	97.5	2.36	60.0
10G-10MBX	7209-40115	5/8	15.9	7/8-14	-	32.0	3.88	98.5	2.40	61.0
12G-12MBX	7209-40145	3/4	19.1	1 1/16-12	-	32.0	4.55	115.5	2.54	64.5

MegaCrimp™ 编织管一体式接头

SAE 直管外螺纹可旋转带 O 型圈密封 45°弯接头

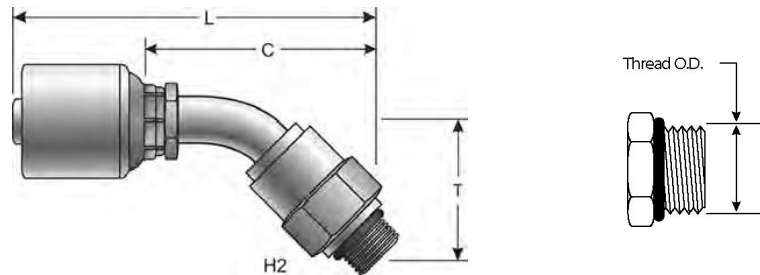

产品描述	编号	⊖		🌀	H1	H2	T		L		C	
		"	mm		mm	mm	"	mm	"	mm	"	mm
6G-6MBX45	7209-40225	3/8	9.5	9/16-18	-	22.0	1.52	38.7	3.65	92.6	2.54	64.6
6G-8MBX45	7209-40235	3/8	9.5	3/4-16	-	24.0	1.52	38.7	3.65	92.6	2.54	64.6
8G-8MBX45	7209-40255	1/2	12.7	3/4-16	-	24.0	1.64	41.7	4.24	107.7	2.77	70.3
8G-10MBX45	7209-40266	1/2	12.7	7/8-14	-	27.0	1.69	42.8	4.28	108.8	2.81	71.3

SAE 直管外螺纹可旋转带 O 型圈密封 90°弯接头

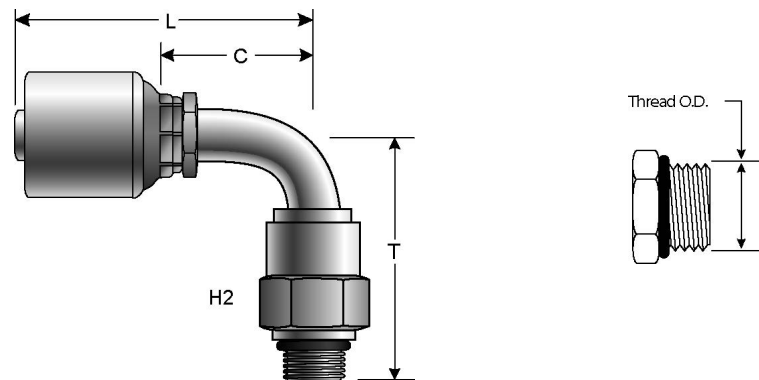

产品描述	编号	⊖		🌀	H1	H2	T		L		C	
		"	mm		mm	mm	"	mm	"	mm	"	mm
4G-6MBX90	7209-40425	1/4	6.4	9/16-18	-	7/8	2.36	60.0	2.19	55.6	1.17	29.6
6G-6MBX90	7209-40455	3/8	9.5	9/16-18	-	7/8	2.48	63.1	2.47	62.8	1.37	34.8
6G-8MBX90	7209-40475	3/8	9.5	3/4-16	-	1	2.48	63.1	2.47	62.8	1.37	34.8
6G-10MBX90	7209-40485	3/8	9.5	7/8-14	-	1	2.37	60.1	2.47	62.8	1.37	34.8
8G-8MBX90	7209-40505	1/2	12.7	3/4-16	-	1	2.76	70.1	3.16	80.3	1.69	42.9
8G-10MBX90	7209-40525	1/2	12.7	7/8-14	-	1	2.82	71.6	3.16	80.3	1.69	42.9
8G-12MBX90	7209-40545	1/2	12.7	1 1/16-12	-	1.26	2.90	73.6	3.16	80.3	1.69	42.9
10G-10MBX90	7209-40585	5/8	15.9	7/8-14	-	1 5/16	3.14	79.8	3.55	90.1	2.07	52.6
10G-12MBX90	7209-40605	5/8	15.9	1 1/16-12	-	1	3.18	80.8	3.55	90.1	2.07	52.6
12G-12MBX90	7209-40645	3/4	19.1	1 1/16-12	-	1 5/16	3.42	86.8	4.33	110.1	2.33	59.1

MegaCrimp™ 编织管一体式接头

JIC 37°外螺纹直接头

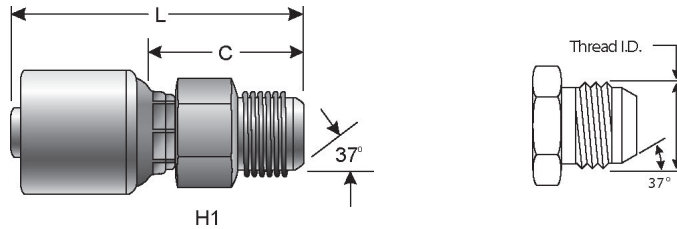

产品描述	编号	⊖		🌀	H1		H2		L		C	
		"	mm		"	mm	"	mm	"	mm	"	mm
4G-4MJ	7103-36045	1/4	6.4	7/16-20	-	14.0	-	-	2.19	55.5	1.16	29.5
4G-5MJ	7103-36055	1/4	6.4	1/2-20	-	14.0	-	-	2.19	55.5	1.16	29.5
4G-6MJ	7103-36065	1/4	6.4	9/16-18	-	17.0	-	-	2.22	56.5	1.20	30.5
5G-5MJ	7103-36105	5/16	7.9	1/2-20	-	17.0	-	-	2.26	57.5	1.16	29.5
5G-6MJ	7103-36115	5/16	7.9	9/16-18	-	17.0	-	-	2.26	57.5	1.16	29.5
6G-6MJ	7103-36155	3/8	9.5	9/16-18	-	17.0	-	-	2.30	58.5	1.20	30.6
6G-8MJ	7103-36165	3/8	9.5	3/4-16	-	19.0	-	-	2.48	63.0	1.38	35.1
6G-10MJ	7103-36175	3/8	9.5	7/8-14	-	24.0	-	-	2.64	67.0	1.54	39.1
8G-8MJ	7103-36215	1/2	12.7	3/4-16	-	22.0	-	-	2.81	71.5	1.34	34.0
8G-10MJ	7103-36225	1/2	12.7	7/8-14	-	24.0	-	-	2.91	74.0	1.11	36.5
8G-12MJ	7103-36235	1/2	12.7	1 1/16-12	-	27.0	-	-	3.19	81.0	1.71	43.5
10G-8MJ	7103-36265	5/8	15.9	3/4-16	-	27.0	-	-	2.93	74.5	1.46	37.0
10G-10MJ	7103-36275	5/8	15.9	7/8-14	-	27.0	-	-	3.03	77.0	1.56	39.5
10G-12MJ	7103-36285	5/8	15.9	1 1/16-12	-	27.0	-	-	3.19	81.0	1.71	43.5
12G-10MJ	7103-36315	3/4	19.1	7/8-14	-	27.0	-	-	3.68	93.5	1.67	42.5
12G-12MJ	7103-36325	3/4	19.1	1 1/16-12	-	27.0	-	-	3.72	94.5	1.71	43.5
12G-14MJ	7103-36335	3/4	19.1	1 3/16-12	-	32.0	-	-	3.76	95.5	1.75	44.5
12G-16MJ	7103-36345	3/4	19.1	1 5/16-12	-	36.0	-	-	3.78	96.0	1.77	45.0
16G-14MJ	7103-36375	1	25.4	1 3/16-12	-	36.0	-	-	4.09	104.0	1.86	47.2
16G-16MJ	7103-36385	1	25.4	1 5/16-12	-	36.0	-	-	4.11	104.5	1.88	47.7
16G-20MJ	7103-36395	1	25.4	1 5/8-12	-	46.0	-	-	4.29	109.0	2.06	52.2
20G-20MJ	7103-36435	1 1/4	31.8	1 5/8-12	-	46.0	-	-	4.43	112.5	2.11	53.5
20G-24MJ	7103-36445	1 1/4	31.8	1 7/8-12	-	50.0	-	-	4.43	112.5	2.11	53.5

MegaCrimp™ 编织管一体式接头

JIC 37°内螺纹直接头

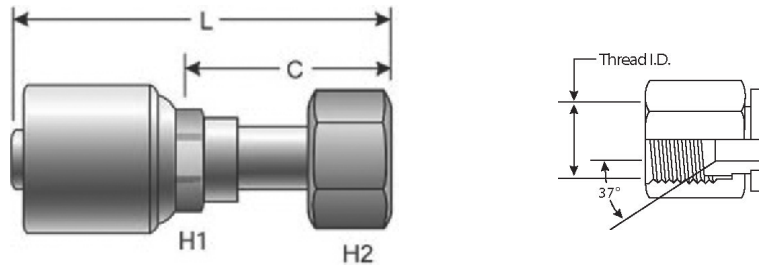

产品描述	编号	⊘		🌀	H1		H2		L		C	
		"	mm		"	mm	"	mm	"	mm	"	mm
4G-4FJX	7103-08045	1/4	6.4	7/16-20	-	15.0	-	14.0	2.20	55.9	1.18	29.9
4G-5FJX	7103-08055	1/4	6.4	1/2-20	-	15.0	-	17.0	2.30	58.3	1.27	32.3
4G-6FJX	7103-08065	1/4	6.4	9/16-18	-	15.0	-	19.0	2.35	59.6	1.32	33.6
5G-6FJX	7103-09105	5/16	7.9	9/16-18	-	17.0	-	19.0	2.50	63.6	1.40	35.6
5G-5FJX	7103-00935	5/16	7.9	1/2-20	-	17.0	-	17.0	2.35	59.7	1.25	31.7
6G-4FJX	7103-09135	3/8	9.5	7/16-20	-	15.9	-	14.0	2.94	74.7	1.84	46.8
6G-5FJX	7103-09125	3/8	9.5	1/2-20	-	17.0	-	17.0	2.96	75.2	1.86	47.3
6G-6FJX	7103-08145	3/8	9.5	9-16-18	-	18.0	-	19.0	2.42	61.5	1.29	32.7
6G-8FJX	7103-08155	3/8	9.5	3/4-16	-	18.0	-	24.0	2.63	66.7	1.49	37.9
6G-10FJX	7103-08165	3/8	9.5	7/8-14	-	18.0	-	27.0	2.76	70.0	1.62	41.2
8G-6FJX	7103-09195	1/2	12.7	9/16-18	-	22.0	-	19.0	3.81	96.7	2.33	59.2
8G-8FJX	7103-08205	1/2	12.7	3/4-16	-	22.0	-	24.0	2.88	73.2	1.50	38.0
8G-10FJX	7103-08215	1/2	12.7	7/8-14	-	22.0	-	27.0	3.01	76.5	1.63	41.3
8G-12FJX	7103-08225	1/2	12.7	1 1/16-12	-	22.0	-	32.0	3.06	77.7	1.67	42.5
8G-16FJX	7103-09235	1/2	12.7	1 5/16-12	-	22.0	-	41.0	3.52	89.3	2.04	51.8
10G-8FJX	7103-09255	5/8	15.9	3/4-16	-	24.0	-	24.0	4.06	103.0	2.58	65.5
10G-10FJX	7103-08265	5/8	15.9	7/8-14	-	24.0	-	27.0	3.14	79.7	1.66	42.2
10G-12FJX	7103-08275	5/8	15.9	1 1/16-12	-	24.0	-	32.0	3.20	81.4	1.73	43.9
10G-14FJX	7103-08285	5/8	15.9	1 3/16-12	-	24.0	-	36.0	3.39	86.1	1.91	48.6
12G-8FJX	7103-10305	3/4	19.1	3/4-16	-	27.0	-	24.0	3.51	89.1	1.50	38.1
12G-10FJX	7103-09315	3/4	19.1	7/8-14	-	27.0	-	27.0	4.80	122.0	2.80	71.0
12G-12FJX	7103-08325	3/4	19.1	1 1/16-12	-	30.0	-	32.0	3.74	95.0	1.73	44.0
12G-14FJX	7103-08335	3/4	19.1	1 3/16-12	-	30.0	-	36.0	3.81	96.9	1.81	45.9
12G-16FJX	7103-08345	1	19.1	1 5/16-12	-	30.0	-	41.0	3.85	97.9	1.85	46.9
16G-12FJX	71030937	1	25.4	1 1/16-12	-	36.0	-	32.0	5.87	149.1	3.64	92.4
16G-16FJX	7103-08395	1	25.4	1 5/16-12	-	36.0	-	41.0	4.24	107.8	2.01	51.0
16G-20FJX	7103-08405	1	25.4	1 5/8-12	-	36.0	-	50.0	4.54	115.3	2.30	58.5
20G-20FJX	71030943	1 1/4	31.8	1 5/8-12	-	50.0	-	50.0	4.76	121.0	2.44	62.0
20G-24FJX	7103-01155	1 1/4	31.8	1 7/8-12	-	41.0	-	60.0	4.85	123.2	2.53	64.2

MegaCrimp™ 编织管一体式接头

JIC 37°内螺纹 45°弯接头

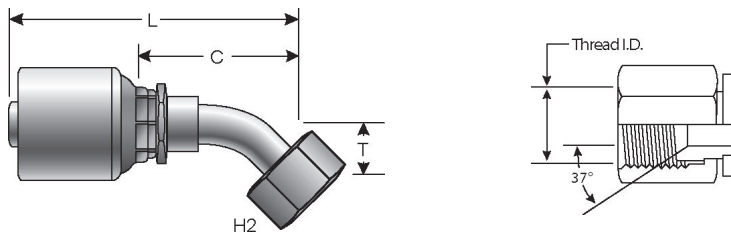

产品描述	编号	⊖		🌀	H1		H2		T		L		C	
		"	mm		"	mm	"	mm	"	mm	"	mm	"	mm
4G-4FJX45S	7103-46055	1/4	6.4	7/16-20	-	-	-	14.0	.39	10.0	2.74	69.7	1.72	43.7
4G-5FJX45-011	7103-46075	1/4	6.4	1/2-20	-	-	-	17.0	.43	11.0	2.59	65.8	1.56	39.7
4G-6FJX45S	7103-46135	1/4	6.4	9/16-18	-	-	-	19.0	.43	11.0	2.69	68.3	1.67	42.3
5G-6FJX45S	7103-46195	5/16	7.9	9/16-18	-	-	-	19.0	.43	11.0	2.85	72.4	1.75	44.4
5G-5FJX45	7103-01265	5/16	7.9	1/2-20	-	-	5/8	-	.56	14.2	2.60	66.0	1.50	38.0
6G-4FJX45S	7103-46215	3/8	9.5	7/16-20	-	-	-	14.0	.39	10.0	2.86	72.7	1.76	44.8
6G-6FJX45S	7103-46235	3/8	9.5	9-16-18	-	-	-	19.0	.43	11.0	3.05	77.5	1.95	49.6
6G-8FJX45S	7103-46255	3/8	9.5	3/4-16	-	-	-	24.0	.59	15.0	3.51	89.1	2.41	61.2
8G-8FJX45S	7103-46295	1/2	12.7	3/4-16	-	-	-	24.0	.59	15.0	3.42	86.9	1.95	49.5
8G-10FJX45S	7103-46315	1/2	12.7	7/8-14	-	-	-	27.0	.63	16.0	3.81	96.8	2.34	59.4
10G-10FJX45S	7103-46355	5/8	15.9	7/8-14	-	-	-	27.0	.63	16.0	3.80	96.4	2.32	59.0
10G-12FJX45S	7103-46375	5/8	15.9	1 1/16-12	-	-	-	32.0	.83	21.0	4.57	116.0	3.09	78.5
12G-10FJX45S	7103-46415	3/4	19.1	7/8-14	-	-	-	27.0	.75	19.0	4.58	116.3	2.57	65.3
12G-12FJX45S	7103-46425	3/4	19.1	1 1/16-12	-	-	-	32.0	.83	21.0	5.09	129.2	3.08	78.2
12G-16FJX45S	7103-46455	3/4	19.1	1 5/16-12	-	-	-	41.0	.94	24.0	5.24	133.1	3.23	82.1
16G-12FJX45S	7103-4649	1	25.4	1 1/16-12	1.40	34.93	1.26	32.0	.83	21.0	5.48	139.2	3.24	82.4
16G-16FJX45S	7103-46505	1	25.4	1 5/16-12	-	-	-	41.0	.94	24.0	5.68	144.3	3.44	87.5
20G-20FJX45-035	7103-4660	1 1/4	31.8	1 5/8-12	1.97	50.0	1.97	50.0	1.38	35.0	6.65	169.0	4.33	110.0

JIC 37°内螺纹 90°弯接头

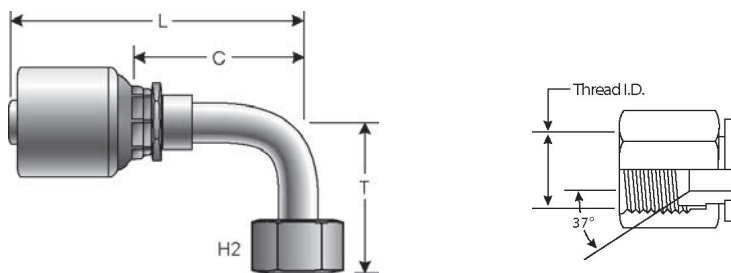

产品描述	编号	⊖		🌀	H1		H2		T		L		C	
		"	mm		"	mm	"	mm	"	mm	"	mm	"	mm
4G-4FJX90L	7103-47065	1/4	6.4	7/16-20	-	-	-	14.0	1.81	46.0	2.48	63.1	1.46	37.1
4G-4FJX90M	7103-47055	1/4	6.4	7/16-20	-	-	-	14.0	1.26	32.0	2.48	63.1	1.46	37.1
4G-4FJX90S	7103-47045	1/4	6.4	7/16-20	-	-	-	14.0	.83	21.0	2.48	63.1	1.46	37.1
4G-4FJX90-023	7103-47075	1/4	6.4	1/2-20	-	-	-	17.0	.91	23.0	2.45	62.2	1.43	36.2
4G-5FJX90L	7103-47105	1/4	6.4	1/2-20	-	-	-	17.0	1.81	46.0	2.25	57.2	1.23	31.2

MegaCrimp™ 编织管一体式接头

JIC 37°内螺纹 90°弯接头

产品描述	编号	⊖			H1		H2		T		L		C	
		"	mm		"	mm	"	mm	"	mm	"	mm	"	mm
4G-5FJX90M	7103-47095	1/4	6.4	1/2-20	-	-	-	17.0	1.26	32.0	2.25	57.2	1.23	31.2
4G-6FJX90L	7103-47145	1/4	6.4	9/16-18	-	-	-	19.0	2.13	54.0	2.73	69.3	1.70	43.2
4G-6FJX90M	7103-47135	1/4	6.4	9/16-18	-	-	-	19.0	1.50	38.0	2.56	64.9	1.53	38.9
4G-6FJX90S	7103-47125	1/4	6.4	9/16-18	-	-	-	19.0	.91	23.0	2.80	71.2	1.78	45.1
5G-6FJX90S	7103-47165	5/16	7.9	9/16-18	-	-	-	19.0	.91	23.0	2.96	75.2	1.86	47.2
5G-6FJX90L	7103-4118	5/16	7.9	9/16-18	-	-	0.69	17.46	-	-	2.52	64.0	1.42	36.0
5G-6FJX90M	7103-4717	5/16	7.9	9/16-18	-	-	0.75	19.0	1.50	38.0	2.99	76.0	1.89	48.0
6G-4FJX90L	7103-47635	3/8	9.5	9/16-18	-	-	-	14.0	1.81	46.0	2.37	60.2	1.27	32.3
6G-4FJX90S	7103-47195	3/8	9.5	7/16-20	-	-	-	14.0	.83	21.0	2.60	66.1	1.50	38.2
6G-6FJX90L	7103-47225	3/8	9.5	7/16-20	-	-	-	19.0	2.13	54.0	2.78	70.6	1.68	42.7
6G-6FJX90M	7103-47215	3/8	9.5	9/16-18	-	-	-	19.0	1.50	38.0	3.01	76.5	1.91	48.5
6G-6FJX90S	7103-47205	3/8	9.5	9/16-18	-	-	-	19.0	.91	23.0	3.09	78.6	1.99	50.7
6G-8FJX90L	7103-47265	3/8	9.5	9/16-18	-	-	-	24.0	2.52	64.0	3.33	84.5	2.23	56.6
6G-8FJX90M	7103-47255	3/8	9.5	3/4-16	-	-	-	24.0	1.61	41.0	3.31	84.1	2.21	56.2
6G-8FJX90S	7103-47245	3/8	9.5	3/4-16	-	-	-	24.0	1.14	29.0	3.18	80.7	2.08	52.8
6G-10FJX90M	7103-47235	3/8	9.5	3/4-16	-	-	-	27.0	1.85	47.0	3.25	82.5	2.15	54.6
8G-8FJX90L	7103-47305	1/2	12.7	7/8-14	-	-	-	24.0	2.52	64.0	3.04	77.3	1.57	39.9
8G-8FJX90M	7103-47295	1/2	12.7	3/4-16	-	-	-	24.0	1.61	41.0	3.04	77.3	1.30	32.9
8G-8FJX90S	7103-47285	1/2	12.7	3/4-16	-	-	-	24.0	1.14	29.0	3.19	81.0	1.71	43.6
8G-10FJX90L	7103-47345	1/2	12.7	3/4-16	-	-	-	27.0	2.76	70.0	3.67	93.3	2.20	55.8
8G-10FJX90M	7103-47335	1/2	12.7	7/8-14	-	-	-	27.0	1.85	47.0	3.67	93.3	2.20	55.8
8G-10FJX90S	7103-47325	1/2	12.7	7/8-14	-	-	-	27.0	1.26	32.0	3.67	93.3	2.20	55.8
8G-12FJX90S	7103-47355	1/2	12.7	7/8-14	-	-	-	32.0	1.22	48.0	2.73	107.5	1.78	70.0
10G-10FJX90-036	7103-47675	5/8	15.9	1 1/16-12	-	-	-	27.0	1.42	36.0	3.50	89.0	2.03	51.5
10G-10FJX90L	7103-47385	5/8	15.9	7/8-14	-	-	-	27.0	2.76	70.0	3.38	85.9	1.91	48.4
10G-10FJX90M	7103-47375	5/8	15.9	7/8-14	-	-	-	27.0	1.85	47.0	3.68	93.4	2.20	55.9
10G-12FJX90L	7103-4742	5/8	15.9	1 1/16-12	-	-	-	32.0	3.78	96.0	4.56	115.7	3.08	78.2
10G-12FJX90M	7103-4741	5/8	15.9	1 1/16-12	-	-	-	32.0	2.28	58.0	4.03	101.9	1.80	64.4
10G-12FJX90S	7103-4740	5/8	15.9	1 1/16-12	-	-	-	32.0	1.89	48.0	4.22	107.3	2.75	69.8
12G-10FJX90M	7103-47435	3/4	19.1	1 1/16-12	-	-	-	27.0	1.85	47.0	4.49	114.1	2.48	63.1
12G-12FJX90L	7103-47465	3/4	19.1	7/8-14	-	-	-	32.0	3.78	96.0	4.82	122.4	2.81	71.4
12G-12FJX90M	7103-47455	3/4	19.1	1 1/16-12	-	-	-	32.0	2.28	58.0	4.82	122.4	2.81	71.4
12G-12FJX90S	7103-47445	3/4	19.1	1 1/16-12	-	-	-	32.0	1.89	48.0	4.82	122.4	2.81	71.4
12G-14FJX90-054	7103-4761	3/4	19.1	1 3/16-12	-	-	-	36.0	2.13	54.0	4.88	124.0	2.87	73.0
12G-14FJX90-100	7103-47625	3/4	19.1	1 1/16-12	-	-	-	36.0	3.94	100.0	4.23	107.4	2.22	56.4
12G-16FJX90M	7103-47515	3/4	19.1	1 3/16-12	-	-	-	41.0	2.80	71.0	4.78	121.3	2.77	70.3
12G-16FJX90S	7103-47475	3/4	19.1	1 5/16-12	-	-	-	41.0	2.20	56.0	5.22	132.7	3.22	81.7
16G-16FJX90L	7103-47505	1	25.4	1 5/16-12	-	-	-	41.0	4.49	114.0	4.74	120.3	2.50	63.5
16G-16FJX90M	7103-47495	1	25.4	1 5/16-12	-	-	-	41.0	2.80	71.0	4.73	120.2	2.50	63.4
16G-16FJX90S	7103-47485	1	25.4	1 5/16-12	-	-	-	41.0	2.20	56.0	5.73	145.6	3.50	88.8
16G-16FJX90S	7103-47485	1	25.4	1 5/16-12	-	-	-	41.0	2.20	56.0	5.73	145.6	3.50	88.8
16G-20FJX90S	7103-47535	1	25.4	1 5/8-12	-	-	-	50.0	2.52	64.0	6.18	157.0	3.94	100.2
20G-20FJX90L	7103-41585	1 1/4	31.8	1 5/8-12	-	-	2	-	5.08	129.0	6.22	158.0	3.90	99.0
20G-20FJX90-089	7103-4759	1 1/4	31.8	1 5/8-12	-	-	-	50	3.50	89.0	6.22	157.8	3.89	98.8
20G-20FJX90M	7103-4757	1 1/4	31.8	1 5/8-12	-	-	-	50	3.07	78.0	6.26	159.0	3.94	100.0

MegaCrimp™ 编织管一体式接头

SAE 45°内螺纹直接头

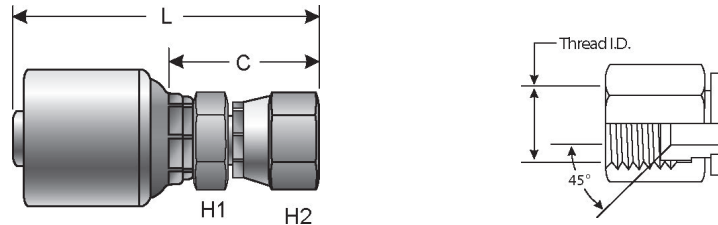

产品描述	编号	⌀		🌀	H1	H2	L		C	
		"	mm		"	"	"	mm	"	mm
4G-4FSX	7100-11885	1/4	6.4	7/16-20	1/2	9/16	2.24	57.0	1.22	31.0
4G-5FSX	7100-11895	1/4	6.4	1/2-20	1/2	11/16	2.21	56.2	1.19	30.2
4G-6FSX	7100-11905	1/4	6.4	5/8-18	5/8	3/4	2.31	58.7	1.28	32.6
5G-6FSX	7100-11935	5/16	7.9	5/8-18	5/8	3/4	2.44	62.1	1.34	34.1
6G-6FSX	7100-11915	3/8	9.5	5/8-18	5/8	3/4	2.44	62.1	1.35	34.2
6G-8FSX	7100-11925	3/8	9.5	3/4-16	11/16	7/8	2.48	63.1	1.38	35.1
8G-8FSX	7100-01935	1/2	12.7	3/4-16	13/16	7/8	2.82	71.6	1.34	34.1
8G-10FSX	7100-01945	1/2	12.7	7/8-14	13/16	1 1/16	2.99	75.9	1.51	38.4
12G-12FSX	7100-01955	3/4	19.1	1 1/16-14	1 1/16	1 1/4	3.68	93.5	1.67	42.5

SAE 45°内螺纹 45°弯接头

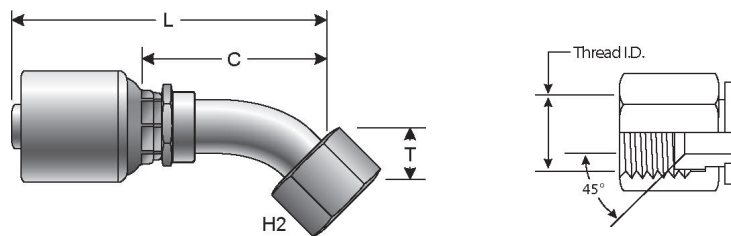

产品描述	编号	⌀		🌀	H1	H2	T	L		C		
		"	mm		"	"	"	mm	"	mm	"	mm
4G-4FSX45	7100-11965	1/4	6.4	7/16-20	-	1 9/16	.33	8.4	2.34	59.5	1.32	33.5
4G-5FSX45-009	7100-01965	1/4	6.4	1/2-20	-	5/8	.36	9.1	2.63	66.9	1.61	40.9
6G-6FSX45	7100-11995	3/8	9.5	5/8-18	-	3/4	.39	9.9	2.74	69.5	1.64	41.6
6G-8FSX45-014	7100-02035	3/8	9.5	3/4-16	-	7/8	.55	14.0	3.46	87.8	2.36	59.9
8G-8FSX45	7100-02015	1/2	12.7	3/4-16	-	7/8	.55	14.0	3.31	84.0	1.83	46.5
8G-10FSX45-016	7100-02055	1/2	12.7	7/8-14	-	1	.63	16.0	3.67	93.1	2.19	55.6
12G-12FSX45	7100-02045	3/4	19.1	1 1/16-14	-	1 1/4	.78	19.8	4.37	111.0	2.36	60.0

MegaCrimp™ 编织管一体式接头

SAE 45°内螺纹 90°弯接头

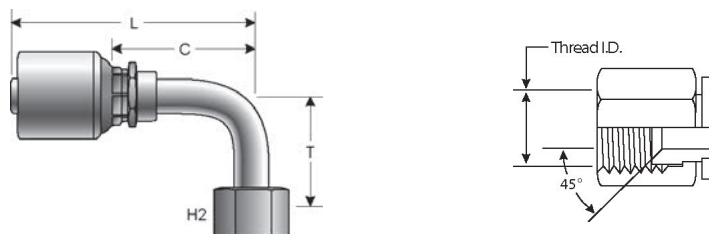

产品描述	编号	⊖		🌀	H1	H2	T		L		C	
		"	mm		"	"	"	mm	"	mm	"	mm
4G-4FSX90	7100-12055	1/4	6.4	7/16-20	-	9/16	1.24	31.5	2.05	52.0	1.02	26.0
4G-5FSX90-046	7100-01985	1/4	6.4	1/2-20	-	5/8	1.80	45.7	2.47	62.8	1.45	36.8
5G-6FSX90-022	7100-02005	5/16	7.9	5/8-18	-	3/4	.85	21.6	2.77	70.4	1.67	42.4
6G-6FSX90	7100-12105	3/8	9.5	5/8-18	-	3/4	1.52	38.5	2.36	60.0	1.26	32.1
6G-6FSX90-055	7100-01995	3/8	9.5	5/8-18	-	3/4	2.18	55.4	2.83	71.8	1.73	43.9
6G-8FSX90	7100-02125	3/8	9.5	3/4-16	-	7/8	1.75	44.5	2.50	63.5	1.40	35.6
8G-8FSX90	7100-02135	1/2	12.7	3/4-16	-	7/8	1.75	44.5	2.93	74.5	1.46	37.0
8G-10FSX90-031	7100-02065	1/2	12.7	7/8-14	-	1	1.23	31.2	3.29	83.5	1.81	46.0
12G-12FSX90	7100-02185	3/4	19.1	1 1/16-14	-	1 1/4	2.78	70.6	3.94	100.0	1.93	49.0

ORFS 平面密封外螺纹直接头

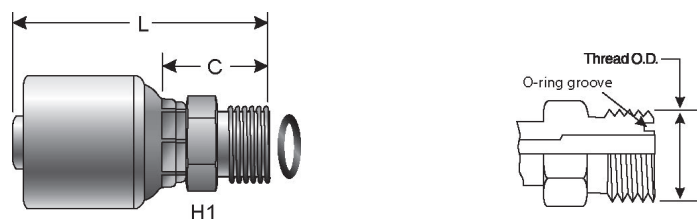

产品描述	编号	⊖		🌀	H1	H2	L		C	
		"	mm		mm	mm	"	mm	"	mm
4G-4MFFOR	7104-16045	1/4	6.4	9/16-18	17.0	17.0	2.07	52.5	1.04	26.5
4G-6MFFOR	7104-16055	1/4	6.4	11/16-16	19.0	19.0	2.13	54.0	1.10	28.0
5G-6MFFOR	7104-16065	5/16	7.9	11/16-16	19.0	19.0	2.20	56.0	1.10	28.0
6G-6MFFOR	7104-16075	3/8	9.5	11/16-16	19.0	19.0	2.20	56.0	1.11	28.1
6G-8MFFOR	7104-16085	3/8	9.5	13/16-16	22.0	22.0	2.32	59.0	1.22	31.1
6G-10MFFOR	7104-16095	3/8	9.5	1-14	27.0	27.0	2.52	64.0	1.42	36.1
8G-8MFFOR	7104-16115	1/2	12.7	13/16-16	22.0	22.0	2.69	68.2	1.21	30.7
8G-10MFFOR	7104-16125	1/2	12.7	1-14	27.0	27.0	2.87	73.0	1.40	35.5
8G-12MFFOR	7104-16135	1/2	12.7	1 3/16-12	32.0	32.0	3.01	76.5	1.54	39.0
10G-10MFFOR	7104-16155	5/8	15.9	1-14	27.0	27.0	2.87	73.0	1.40	35.5
10G-12MFFOR	7104-16165	5/8	15.9	1 3/16-12	32.0	32.0	3.03	77.0	1.56	39.5
12G-12MFFOR	7104-16185	3/4	19.1	1 3/16-12	32.0	32.0	3.54	90.0	1.54	39.0
12G-16MFFOR	7104-16195	3/4	19.1	1 7/16-12	41.0	41.0	3.74	95.0	1.73	44.0
16G-16MFFOR	7104-16215	1	25.4	1 7/16-12	41.0	41.0	4.02	102.0	1.78	45.2
16G-20MFFOR	7104-16225	1	25.4	1 11/16-12	46.0	46.0	4.13	105.0	1.90	48.2
20G-20MFFOR	7104-16245	1 1/4	31.8	1 11/16-12	46.0	46.0	4.29	109.0	1.97	50.0

MegaCrimp™ 编织管一体式接头

ORFS 平面密封内螺纹直接头

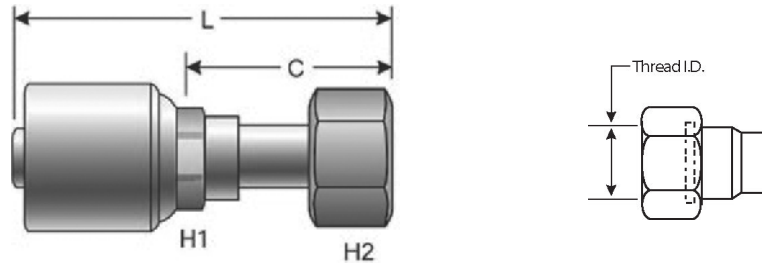

产品描述	编号	⊘		🌀	H1		H2		L		C	
		"	mm		"	mm	"	mm	"	mm	"	mm
4G-4FFORX	7104-18045	1/4	6.4	9/16-18	-	15.0	-	17.0	2.07	52.7	1.05	26.7
4G-6FFORX	7104-18055	1/4	6.4	11/16-16	-	15.0	-	22.0	2.01	51.1	.99	25.1
4G-8FFORX	7104-18075	1/4	6.4	13/16-16	-	15.0	-	24.0	1.99	50.5	.96	24.5
5G-6FFORX	7104-19505	5/16	7.9	11/16-16	-	17.0	-	22.0	2.42	61.5	1.32	33.5
6G-4FFORX	7104-19085	3/8	9.5	9/16-18	-	17.0	-	17.0	3.08	78.3	1.98	50.3
6G-6FFORX	7104-18095	3/8	9.5	11/16-16	-	18.0	-	22.0	2.27	57.7	1.14	28.9
6G-8FFORX	7104-18105	3/8	9.5	13/16-16	-	18.0	-	24.0	2.26	57.4	1.13	28.6
6G-10FFORX	7104-18115	3/8	9.5	1-14	-	18.0	-	30.0	2.15	54.7	1.02	25.9
8G-6FFORX	7104-19145	1/2	12.7	11/16-16	-	22.0	-	22.0	3.78	95.9	2.30	58.4
8G-8FFORX	7104-18155	1/2	12.7	13/16-16	-	22.0	-	24.0	2.62	66.5	1.23	31.3
8G-10FFORX	7104-18165	1/2	12.7	1-14	-	22.0	-	30.0	2.76	70.0	1.37	34.8
8G-12FFORX	7104-18175	1/2	12.7	1 3/16-12	-	22.0	-	36.0	2.81	71.5	1.43	36.3
10G-8FFORX	7104-19195	5/8	15.9	13/16-16	-	24.0	-	24.0	3.83	97.2	2.35	59.7
10G-10FFORX	7104-18205	5/8	15.9	1-14	-	24.0	-	30.0	2.99	76.0	1.52	38.5
10G-12FFORX	7104-18215	5/8	15.9	1 3/16-12	-	24.0	-	36.0	3.03	77.0	1.56	39.5
12G-10FFORX	7104-19245	3/4	19.1	1-14	-	30.0	-	30.0	3.74	95.1	1.74	44.1
12G-12FFORX	7104-18255	3/4	19.1	1 3/16-12	-	30.0	-	36.0	3.65	92.8	1.65	41.8
12G-16FFORX	7104-18265	3/4	19.1	1 7/16-12	-	30.0	-	41.0	3.48	88.3	1.47	37.3
16G-12FFORX	7104-19295	1	25.4	1 3/16-12	-	36.0	-	36.0	5.58	141.8	3.35	85.0
16G-20FFORX	7104-18315	1	25.4	1 11/16-12	-	36.0	-	50.0	4.06	103.0	1.82	46.2
16G-16FFORX	7102-03925	1	25.4	1 7/16-12	-	41.0	1 5/8	-	4.33	110.0	2.09	53.2
20G-24FFORX	7104-19385	1 1/4	31.8	2-12	-	50.0	-	60.0	4.49	114.0	2.17	55.0
20G-20FFORX	7104-29355	1 1/4	31.8	1 11/16-12	-	50.0	-	50.0	4.63	117.5	2.30	58.5

ORFS 平面密封内螺纹 30°弯接头

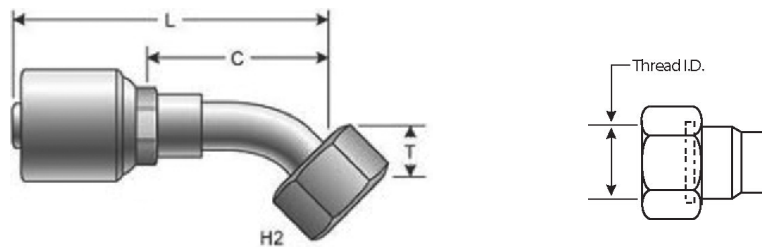

产品描述	编号	⊘		🌀	H1	H2	T		L		C	
		"	mm		mm	mm	"	mm	"	mm	"	mm
8G-10FFORX30-010	7104-07025	1/2	12.7	1-14	22.0	30.0	.38	9.7	3.65	92.7	2.18	55.3

MegaCrimp™ 编织管一体式接头

ORFS 平面密封内螺纹 45°弯接头

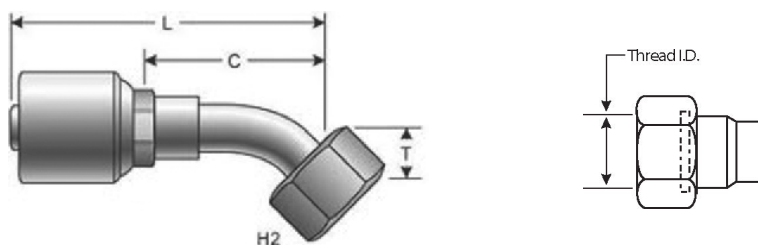

产品描述	编号	⊖		🌀	H1	H2	T		L		C	
		"	mm				"	mm	"	mm	"	mm
4G-4FFORX45S	7104-22045	1/4	6.4	9/16-18	14.0	17.0	.39	10.0	2.57	65.2	1.54	39.2
4G-6FFORX45S	7104-22055	1/4	6.4	11/16-16	14.0	22.0	.43	11.0	2.70	68.5	1.67	42.5
5G-6FFORX45S	7104-22335	5/16	7.9	11/16-16	17.0	22.0	.43	11.0	2.73	69.4	1.63	41.4
6G-4FFORX45S	7104-22075	3/8	9.5	9/16-18	17.0	17.0	.39	10.0	2.60	66.1	1.50	38.1
6G-6FFORX45S	7104-22085	3/8	9.5	11/16-16	17.0	22.0	.43	11.0	2.75	69.8	1.65	41.9
6G-8FFORX45S	7104-22095	3/8	9.5	13/16-16	17.0	24.0	.59	15.0	3.35	85.2	2.26	57.3
8G-6FFORX45S	7104-22125	1/2	12.7	11/16-16	22.0	22.0	.43	11.0	3.57	90.7	2.09	53.2
8G-8FFORX45S	7104-22135	1/2	12.7	13/16-16	22.0	24.0	.59	15.0	3.50	89.0	2.03	51.6
8G-10FFORX45S	7104-22145	1/2	12.7	1-14	22.0	30.0	.63	16.0	3.98	101.0	2.50	63.5
8G-12FFORX45S	7104-22155	1/2	12.7	1 3/16-12	22.0	36.0	.83	21.0	4.34	110.3	2.87	72.8
10G-8FFORX45S	7104-22165	5/8	15.9	1 3/16-12	24.0	24.0	.59	15.0	3.81	96.8	2.33	59.3
10G-10FFORX45S	7104-22175	5/8	15.9	1-14	24.0	30.0	.63	16.0	3.96	100.5	2.48	63.0
10G-12FFORX45S	7104-22185	5/8	15.9	1 3/16-12	24.0	36.0	.83	21.0	4.17	105.9	2.69	68.4
12G-10FFORX45S	7104-22215	3/4	19.1	1-14	30.0	30.0	.63	16.0	4.45	113.0	2.44	62.0
12G-12FFORX45S	7104-22225	3/4	19.1	1 3/16-12	30.0	36.0	.83	21.0	4.66	118.4	2.65	67.4
12G-16FFORX45S	7104-22235	3/4	19.1	1 7/16-12	30.0	41.0	.94	24.0	4.80	122.0	2.80	71.0
16G-12FFORX45S	7104-22255	1	25.4	1 3/16-12	36.0	36.0	.83	21.0	5.33	135.5	2.98	75.7
16G-16FFORX45S	7104-22265	1	25.4	1 7/16-12	36.0	41.0	.94	24.0	5.78	146.9	3.55	90.1
20G-20FFORX45S	7104-22295	1 1/4	31.8	1 11/16-12	50.0	50.0	.98	25.0	6.22	158.0	3.90	99.0

ORFS 平面密封内螺纹 90°弯接头

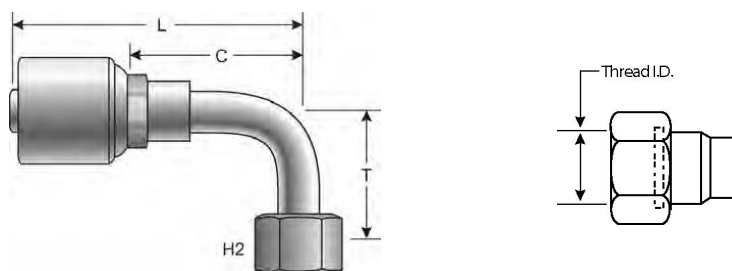

产品描述	编号	⊖		🌀	H1	H2	T		L		C	
		"	mm				"	mm	"	mm	"	mm
4G-4FFORX90L	7104-24065	1/4	6.4	9/16-18	14.0	17.0	1.81	46.0	2.21	56.2	1.19	30.2
4G-4FFORX90M	7104-24055	1/4	6.4	9/16-18	14.0	17.0	1.26	32.0	2.21	56.2	1.19	30.2
4G-4FFORX90S	7104-24045	1/4	6.4	9/16-18	14.0	17.0	.83	21.0	2.37	60.2	1.35	34.2
4G-6FFORX90L	7104-24115	1/4	6.4	11/16-16	14.0	22.0	2.13	54.0	2.43	61.6	1.40	35.6
4G-6FFORX90M	7104-24105	1/4	6.4	11/16-16	14.0	22.0	1.50	38.0	2.50	63.4	1.47	37.4
4G-6FFORX90S	7104-24095	1/4	6.4	11/16-16	14.0	22.0	.91	23.0	2.50	63.4	1.47	37.4

MegaCrimp™ 编织管一体式接头

ORFS 平面密封内螺纹 90°弯接头

产品描述	编号	⊖			H1	H2	T		L		C	
		"	mm				"	mm	"	mm	"	mm
4G-8FFORX90L	7104-24165	1/4	6.4	13/16-16	14.0	24.0	2.52	64.0	2.64	67.1	1.62	41.1
4G-8FFORX90S	7104-24145	1/4	6.4	13/16-16	14.0	24.0	1.14	29.0	2.83	72.0	1.81	46.0
5G-6FFORX90S	7104-24955	5/16	7.9	11/16-16	17.0	22.0	.91	23.0	2.83	72.0	1.73	44.0
6G-4FFORX90S	7104-24195	3/8	9.5	9/16-18	17.0	17.0	.83	21.0	2.42	61.4	1.32	33.6
6G-6FFORX90L	7104-24265	3/8	9.5	11/16-16	17.0	22.0	2.13	54.0	2.73	69.3	1.63	41.4
6G-6FFORX90M	7104-24255	3/8	9.5	11/16-16	17.0	22.0	1.50	38.0	2.50	63.6	1.41	35.7
6G-6FFORX90S	7104-24245	3/8	9.5	11/16-16	17.0	22.0	.91	23.0	2.85	72.5	1.76	44.6
6G-8FFORX90L	7104-24315	3/8	9.5	13/16-16	17.0	24.0	2.52	64.0	2.72	69.0	1.62	41.1
6G-8FFORX90M	7104-24305	3/8	9.5	13/16-16	17.0	24.0	1.61	41.0	2.70	68.5	1.60	40.6
6G-8FFORX90S	7104-24295	3/8	9.5	13/16-16	17.0	24.0	1.14	29.0	2.87	73.0	1.78	45.1
8G-6FFORX90L	7104-24365	1/2	12.7	11/16-16	22.0	22.0	2.13	54.0	3.16	80.3	1.69	42.8
8G-6FFORX90S	7104-24345	1/2	12.7	11/16-16	22.0	22.0	.91	23.0	3.29	83.5	1.81	46.0
8G-8FFORX90L	7104-24415	1/2	12.7	13/16-16	22.0	24.0	2.52	64.0	3.30	83.9	1.83	46.5
8G-8FFORX90M	7104-24405	1/2	12.7	13/16-16	22.0	24.0	1.61	41.0	3.30	83.9	1.83	46.5
8G-8FFORX90S	7104-24395	1/2	12.7	13/16-16	22.0	24.0	1.14	29.0	3.30	83.9	1.83	46.5
8G-10FFORX90L	7104-24465	1/2	12.7	1-14	22.0	30.0	2.76	70.0	3.57	90.6	2.09	53.1
8G-10FFORX90M	7104-24455	1/2	12.7	1-14	22.0	30.0	1.85	47.0	3.67	93.2	2.19	55.7
8G-10FFORX90S	7104-24445	1/2	12.7	1-14	22.0	30.0	1.26	32.0	3.66	92.9	2.18	55.4
8G-12FFORX90S	7104-24475	1/2	12.7	1 3/16-12	22.0	36.0	1.89	48.0	4.05	102.9	2.57	65.4
10G-8FFORX90L	7104-24515	5/8	15.9	1 3/16-16	24.0	24.0	2.52	64.0	3.64	92.4	2.16	54.9
10G-8FFORX90S	7104-24495	5/8	15.9	1 3/16-16	24.0	24.0	1.14	29.0	3.64	92.4	2.16	54.9
10G-10FFORX90L	7104-24565	5/8	15.9	1-14	24.0	30.0	2.76	70.0	3.55	90.2	2.07	52.7
10G-10FFORX90M	7104-24555	5/8	15.9	1-14	24.0	30.0	1.85	47.0	3.65	92.8	2.18	55.3
10G-10FFORX90S	7104-24545	5/8	15.9	1-14	24.0	30.0	1.26	32.0	3.64	92.5	2.17	55.0
10G-12FFORX90S	7104-24595	5/8	15.9	1 3/16-12	24.0	36.0	1.89	48.0	3.79	96.3	2.31	58.8
12G-10FFORX90S	7104-24635	3/4	19.1	1-14	30.0	30.0	1.26	32.0	4.09	104.0	2.09	53.0
12G-12FFORX90L	7104-24665	3/4	19.1	1 3/16-12	30.0	36.0	3.78	96.0	4.65	118.2	2.65	67.2
12G-12FFORX90M	7104-24655	3/4	19.1	1 3/16-12	30.0	36.0	2.28	58.0	4.29	109.0	2.28	58.0
12G-12FFORX90S	7104-24645	3/4	19.1	1 3/16-12	30.0	36.0	1.89	48.0	4.28	108.8	2.28	57.8
12G-16FFORX90S	7104-24695	3/4	19.1	1 7/16-12	30.0	41.0	2.20	56.0	5.06	128.5	3.05	77.5
16G-12FFORX90S	7104-24735	1	25.4	1 3/16-12	36.0	36.0	1.89	48.0	5.09	129.4	2.86	72.6
16G-16FFORX90L	7104-24765	1	25.4	1 7/16-12	36.0	41.0	4.49	114.0	5.11	129.9	2.88	73.1
16G-16FFORX90M	7104-24755	1	25.4	1 7/16-12	36.0	41.0	2.80	71.0	5.11	129.9	2.88	73.1
16G-16FFORX90S	7104-24745	1	25.4	1 7/16-12	36.0	41.0	2.20	56.0	5.11	129.9	2.88	73.1
16G-20FFORX90M	7104-24915	1	25.4	1 11/16-12	36.0	50.0	3.07	78.0	6.14	156.0	3.91	99.2
16G-20FFORX90S	7104-24905	1	25.4	1 11/16-12	36.0	50.0	2.52	64.0	5.11	129.9	2.88	73.1
20G-20FFORX90L	7104-24815	1 1/4	31.8	1 11/16-12	50.0	50.0	5.08	129.0	5.51	140.0	3.19	81.0
20G-20FFORX90M	7104-24805	1 1/4	31.8	1 11/16-12	50.0	50.0	3.07	78.0	5.51	140.0	3.19	81.0
20G-20FFORX90S	7104-24795	1 1/4	31.8	1 11/16-12	50.0	50.0	2.52	64.0	5.91	150.0	3.58	91.0

MegaCrimp™ 编织管一体式接头

SAE-61 轻型法兰直接头

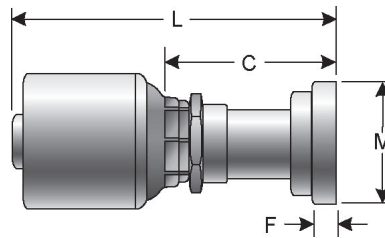

产品描述	编号	⊖		M		L		C		F	
		"	mm	"	mm	"	mm	"	mm	"	mm
8G-8FL	7103-25055	1/2	12.7	1.19	30.2	3.15	80.0	1.67	42.5	.27	6.9
8G-12FL	7103-25105	1/2	12.7	1.50	38.1	3.15	80.0	1.67	42.5	.27	6.9
12G-12FL	7103-25205	3/4	19.1	1.50	38.1	3.86	98.0	1.85	47.0	.27	6.9
12G-16FL	7103-25255	3/4	19.1	1.75	44.5	3.50	88.8	1.49	37.8	.32	8.1
16G-12FL	7103-25295	1	25.4	1.50	38.1	5.04	128.0	2.80	71.2	.27	6.9
16G-16FL	7103-25305	1	25.4	1.75	44.5	4.13	105.0	1.90	48.2	.32	8.1
16G-20FL	7103-25355	1	25.4	2.00	50.8	4.13	105.0	1.90	48.2	.32	8.1
16G-24FL	7103-03875	1	25.4	2.38	60.5	3.78	96.0	1.54	39.2	.32	8.1
20G-20FL	7103-25405	1 1/4	31.8	2.00	50.8	4.43	112.5	2.11	53.5	.32	8.1
20G-24FL	7103-25455	1 1/4	31.8	2.38	60.5	4.63	117.5	2.30	58.5	.32	8.1

SAE-61 轻型法兰 22¹/₂°弯接头

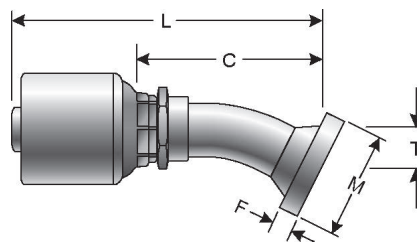

产品描述	编号	⊖		M		T		L		C		F	
		"	mm	"	mm	"	mm	"	mm	"	mm	"	mm
12G-12FL22M	7103-26155	3/4	19.1	1.50	38.1	.43	11.0	4.76	121.0	2.76	70.0	.27	6.9
12G-16FL22M-014	7103-03955	3/4	19.1	1.75	44.5	.55	14.0	4.76	121.0	2.76	70.0	.32	8.1
16G-16FL22M	7103-26255	1	25.4	1.75	44.5	.55	14.0	5.61	142.5	3.37	85.7	.32	8.1
20G-20FL22M	7103-26355	1 1/4	31.8	2.00	50.8	.59	15.0	6.00	152.5	3.68	93.5	.32	8.1

MegaCrimp™ 编织管一体式接头

SAE-61 轻型法兰 30°弯接头

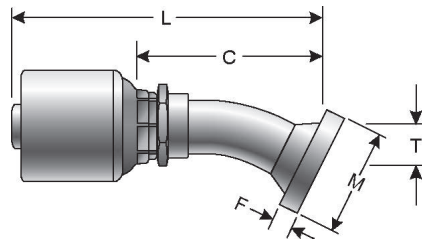

产品描述	编号	⊖		M		T		L		C		F	
		"	mm	"	mm	"	mm	"	mm	"	mm	"	mm
12G-12FL30M	7103-26655	3/4	19.1	15.0	38.1	.63	16.0	4.70	119.5	2.70	68.5	.32	8.1
12G-16FL30M	7103-04045	3/4	19.1	1.75	44.5	.75	19.0	4.88	124.0	2.87	73.0	.32	8.1
16G-16FL30M	7103-26755	1	25.4	1.75	44.5	.75	19.0	5.69	144.5	3.45	87.7	.32	8.1
16G-20FL30M	7103-26805	1	25.4	2.00	50.8	.87	22.0	5.89	149.5	3.65	92.7	.32	8.1
20G-20FL30S	7103-26845	1 1/4	31.8	2.00	50.8	.79	20.0	6.04	153.4	3.72	94.4	.32	8.1

SAE-61 轻型法兰 45°弯接头

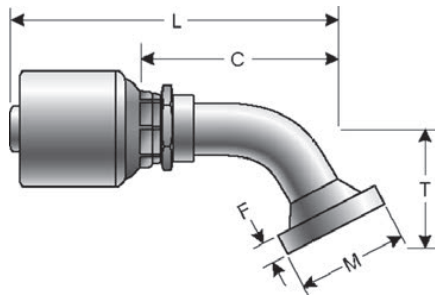

产品描述	编号	⊖		M		T		L		C		F	
		"	mm	"	mm	"	mm	"	mm	"	mm	"	mm
8G-8FL45M	7103-27085	1/2	12.7	1.19	30.2	.75	19.0	3.85	97.8	2.37	60.3	.26	6.6
8G-12FL45M	7103-27165	1/2	12.7	1.50	38.1	1.02	26.0	4.13	104.8	2.65	67.3	.27	6.9
10G-12FL45M	7103-27205	5/8	15.9	1.50	38.1	1.02	26.0	4.43	112.6	2.96	75.1	.26	6.6
12G-12FL45M	7103-27245	3/4	19.1	1.50	38.1	1.02	26.0	4.82	122.5	2.81	71.5	.27	6.9
12G-16FL45S	7103-27315	3/4	19.1	1.75	44.5	1.10	28.0	4.90	124.5	2.89	73.5	.32	8.1
16G-16FL45S	7103-27395	1	25.4	1.75	44.5	1.10	28.0	5.61	142.5	3.37	85.7	.32	8.1
16G-20FL45S	7103-27475	1	25.4	2.00	50.8	1.26	32.0	5.87	149.0	3.63	92.2	.32	8.1
16G-24FL45	7100-07185	1	25.4	2.38	60.5	1.06	26.9	5.30	134.5	3.06	77.7	.32	8.1
20G-20FL45S	7103-27555	1 1/4	31.8	2.00	50.8	1.26	32.0	6.18	157.0	3.86	98.0	.32	8.1

MegaCrimp™ 编织管一体式接头

SAE-61 轻型法兰 60°弯接头

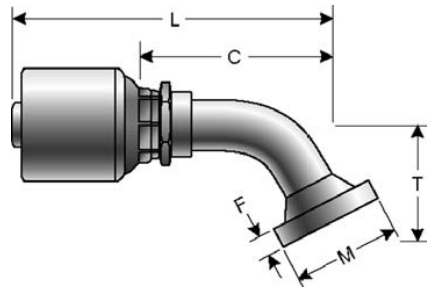

产品描述	编号	⊖		M		T		L		C		F	
		"	mm	"	mm	"	mm	"	mm	"	mm	"	mm
12G-12FL60M	7103-28155	3/4	19.1	1.50	38.1	1.46	37.0	5.05	128.0	3.03	77.0	.27	6.9
12G-16FL60M	7103-28205	3/4	19.1	1.75	44.5	1.73	44.0	5.20	132.0	3.19	81.0	.32	8.1
16G-16FL60M	7103-28255	1	25.4	1.75	44.5	1.73	44.0	5.85	148.5	3.61	91.7	.32	8.1
20G-20FL60S	7103-28345	1 1/4	31.8	2.00	50.8	1.77	45.0	6.22	158.0	3.90	99.0	.32	8.1

SAE-61 轻型法兰 67 1/2°弯接头

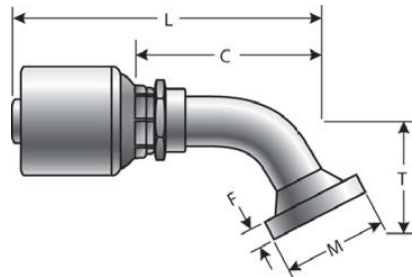

产品描述	编号	⊖		M		T		L		C		F	
		"	mm	"	mm	"	mm	"	mm	"	mm	"	mm
12G-12FL67M	7100-04355	3/4	19.1	1.50	38.1	1.65	42.0	4.65	118.0	2.64	67.0	.27	6.9
20G-20FL67S	7100-04335	1 1/4	31.8	2.00	50.8	2.01	51.0	5.92	150.4	3.60	91.4	.32	8.1

MegaCrimp™ 编织管一体式接头

SAE-61 轻型法兰 90°弯接头

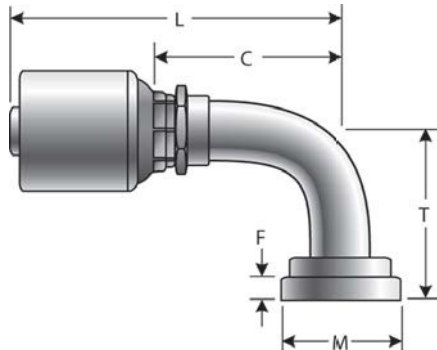

产品描述	编号	⊖		M		T		L		C		F	
		"	mm	"	mm	"	mm	"	mm	"	mm	"	mm
8G-8FL90M	7103-29115	1/2	12.7	1.19	30.2	1.57	40.0	3.59	91.2	2.11	53.7	.27	6.9
8G-12FL90M	7103-29235	1/2	12.7	1.50	38.1	2.28	58.0	3.60	91.5	2.13	54.0	.27	6.9
10G-12FL90M	7100-04485	5/8	15.9	1.50	38.1	2.28	58.0	3.94	100.0	2.46	62.5	.27	6.9
12G-12FL90M	7103-29535	3/4	19.1	1.50	38.1	2.28	58.0	4.54	115.3	2.53	64.3	.27	6.9
12G-16FL90S	7103-29585	3/4	19.1	1.75	44.5	2.40	61.0	4.72	119.8	2.71	68.8	.32	8.1
16G-12FL90M	7103-29655	1	25.4	1.50	38.1	2.28	58.0	5.09	129.3	2.85	72.5	.27	6.9
16G-16FL90S	7103-29705	1	25.4	1.75	44.5	2.40	61.0	5.48	139.3	3.25	82.5	.32	8.1
16G-20FL90S	7103-29765	1	25.4	2.00	50.8	2.68	68.0	5.48	139.3	3.25	82.5	.32	8.1
16G-24FL90S-081	7100-04555	1	25.4	2.38	60.5	3.19	81.0	5.57	141.6	3.34	84.8	.32	8.1
20G-20FL90-102	7100-04565	1 1/4	31.8	2.00	50.8	4.00	101.6	5.43	138.0	3.11	79.0	.32	8.1
20G-20FL90M	7103-29895	1 1/4	31.8	2.00	50.8	3.54	90.0	5.31	135.0	2.99	76.0	.32	8.1
20G-20FL90S	7103-29885	1 1/4	31.8	2.00	50.8	2.68	68.0	6.22	158.1	3.90	99.1	.32	8.1
20G-24FL90S	7103-29945	1 1/4	31.8	2.38	60.5	3.19	81.0	6.22	158.1	3.90	99.1	.32	8.1

BSPT 英制锥管外螺纹直接头

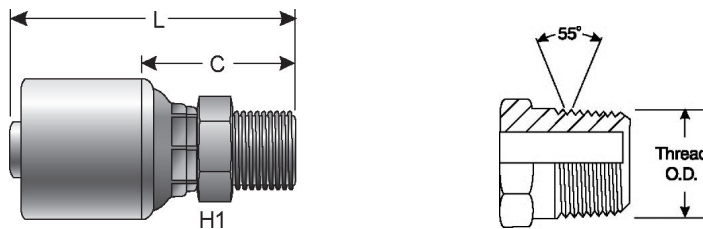

产品描述	编号	⊖		🌀	H1	H2	L		C	
		"	mm		mm	mm	"	mm	"	mm
4G-4MBSPT	7100-91075	1/4	6.4	1/4-19	14.0	-	1.89	47.9	.97	24.8
6G-6MBSPT	7100-91105	3/8	9.5	3/8-19	19.0	-	1.95	49.5	1.03	26.1
8G-8MBSPT	7100-91125	1/2	12.7	1/2-14	22.0	-	2.49	63.4	1.22	30.9
12G-12MBSPT	7100-91145	3/4	19.1	3/4-14	32.0	-	2.92	74.1	1.41	35.7
16G-16MBSPT	7100-91155	1	25.4	1-11	36.0	-	3.44	87.5	1.64	41.6

MegaCrimp™ 编织管一体式接头

BSP 英制直管外螺纹直接头

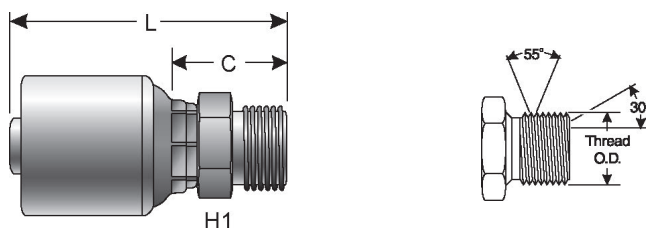

产品描述	编号	⊙		🌀	H1	H2	L		C	
		"	mm				"	mm	"	mm
4G-4MBSPP	7100-15515	1/4	6.4	1/4-19	19.0	-	2.03	51.5	1.00	25.5
6G-4MBSPP	7100-98255	3/8	9.5	1/4-19	19.0	-	2.05	52.0	.95	24.1
6G-6MBSPP	7100-15525	3/8	9.5	3/8-19	22.0	-	2.17	55.0	1.07	27.1
6G-8MBSPP	7100-15535	3/8	9.5	1/2-14	27.0	-	2.36	60.0	1.26	32.1
8G-6MBSPP	7100-93245	1/2	12.7	3/8-19	22.0	-	2.30	58.5	1.02	26.0
8G-8MBSPP	7100-05545	1/2	12.7	1/2-14	27.0	-	2.72	69.0	1.24	31.5
10G-10MBSPP	7100-05555	5/8	15.9	5/8-14	30.0	-	2.89	73.5	1.42	36.0
12G-12MBSPP	7100-05565	3/4	19.1	3/4-14	32.0	-	3.35	85.0	1.34	34.0
16G-16MBSPP	7100-05575	1	25.4	1-11	41.0	-	3.98	101.0	1.74	44.2
20G-20MBSPP	7100-05585	1 1/4	31.8	1 1/4-11	50.0	-	4.33	110.0	2.01	51.0

BSP 直管内螺纹 60°锥带 O 型圈直接头

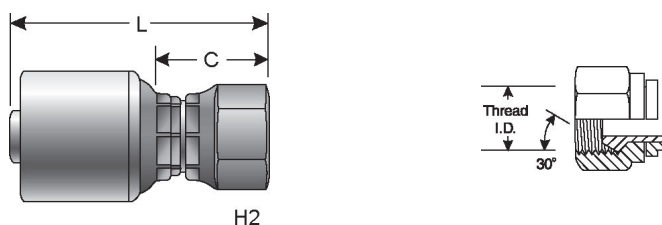

产品描述	编号	⊙		🌀	H1	H2	L		C	
		"	mm				"	mm	"	mm
4G-4FBSPORX	71009591	1/4	6.4	1/4-19	-	19	1.69	43	0.67	17
4G-6FBSPORX	71009592	1/4	6.4	3/8-19	-	22	1.73	44	0.71	18
5G-6FBSPORX	71009502	5/16	7.9	3/8-19	-	22	1.81	46	0.71	18
5G-8FBSPORX	71009503	5/16	7.9	1/2-14	-	27	1.81	46	0.71	18
6G-6FBSPORX	71009629	3/8	9.5	3/8-19	-	22	1.74	44.1	0.64	16.2
6G-8FBSPORX	71009505	3/8	9.5	1/2-14	-	27	1.81	46	0.71	18.1
8G-6FBSPORX	71009789	1/2	12.7	3/8-19	-	22	2.33	59.2	0.85	21.7
8G-8FBSPORX	71009653	1/2	12.7	1/2-14	-	27	2.18	55.3	0.70	17.8
8G-10FBSPORX	71009654	1/2	12.7	5/8-14	-	30	2.25	57.2	0.78	19.7
8G-12FBSPORX	71009509	1/2	12.7	3/4-14	-	32	2.32	59	0.85	21.5
10G-10FBSPORX	71009510	5/8	15.9	5/8-14	-	30	2.23	56.6	0.75	19.1
10G-12FBSPORX	71009948	5/8	15.9	3/4-14	-	32	2.28	58	0.81	20.5
12G-12FBSPORX	71009554	3/4	19.1	3/4-14	-	32	2.80	71	0.79	20
12G-16FBSPORX	71009678	3/4	19.1	1-11	-	41	2.90	73.6	0.89	22.6
16G-16FBSPORX	71009515	1	25.4	1-11	-	41	3.30	83.8	1.06	27
20G-20FBSPORX	71009523	1 1/4	31.8	1 1/4-11	-	50	3.48	88.5	1.16	29.5

MegaCrimp™ 编织管一体式接头

BSP 直管内螺纹 60°锥带 O 型圈 45°弯接头

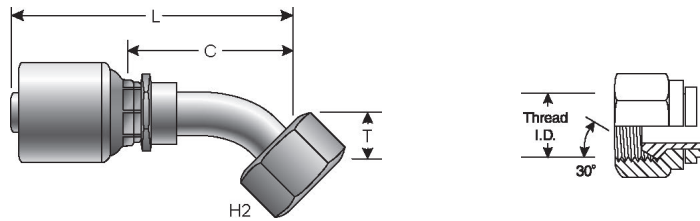

产品描述	编号	⊘		🌀	H1	H2	T		L		C	
		"	mm		mm	mm	"	mm	"	mm	"	mm
4G-4FBSPORX45	7100-9593	1/4	6.4	1/4-19	-	19	0.46	11.65	2.27	57.66	1.25	31.63
6G-6FBSPORX45	7100-9631	3/8	9.5	3/8-19	-	22	0.61	15.38	2.64	67.07	1.54	39.1
6G-8FBSPORX45	7100-9632	3/8	9.5	1/2-14	-	27	0.76	19.27	2.79	70.96	1.69	43
8G-8FBSPORX45	7100-9149	1/2	12.7	1/2-14	-	27	0.67	17	3.01	76.5	1.73	44
8G-10FBSPORX45	7100-9657	1/2	12.7	5/8-14	-	30	0.91	23	3.53	89.77	2.06	52.3
10G-10FBSPORX45	7100-9945	5/8	15.9	5/8-14	-	30	0.84	21.34	3.53	89.58	2.05	52.1
10G-12FBSPORX45	7100-9949	5/8	15.9	3/4-14	-	32	1.23	31.24	3.92	99.48	2.44	62
12G-12FBSPORX45	7100-9152	3/4	19.1	3/4-14	-	32	1.11	28.3	4.05	102.9	2.54	64.4
16G-16FBSPORX45	7100-9153	1	25.4	1-11	-	41	1.21	30.86	5.34	135.59	3.10	78.8
20G-20FBSPORX45	7100-9271	1 1/4	31.8	1 1/4-11	-	50	1.48	37.51	6.38	161.94	4.05	102.9

BSP 直管内螺纹 60°锥带 O 型圈 90°弯接头

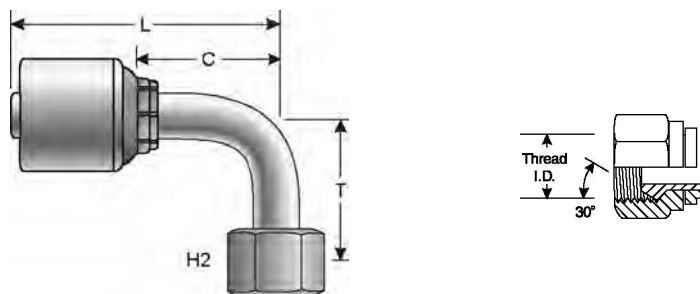

产品描述	编号	⊘		🌀	H1	H2	T		L		C	
		"	mm		mm	mm	"	mm	"	mm	"	mm
4G-4FBSPORX90	7100-9595	1/4	6.4	1/4-19	-	19	0.93	23.5	2.09	53.04	1.06	27
6G-6FBSPORX90	7100-9633	3/8	9.5	3/8-19	-	22	1.26	32	2.44	61.94	1.34	34
6G-8FBSPORX90	7100-9634	3/8	9.5	1/2-14	-	27	1.48	37.5	2.37	60.14	1.27	32.2
8G-8FBSPORX90	7100-9658	1/2	12.7	1/2-14	-	27	1.48	37.5	3.07	77.96	1.59	40.5
8G-10FBSPORX90	7100-9659	1/2	12.7	5/8-14	-	30	1.81	46	3.16	80.24	1.69	42.8
10G-10FBSPORX90	7100-9160	5/8	15.9	5/8-14	-	30	1.81	46	3.00	76.3	1.83	46.6
10G-12FBSPORX90	7100-9950	5/8	15.9	3/4-14	-	32	2.36	60	3.31	84.06	1.83	46.6
12G-12FBSPORX90	7100-9162	3/4	19.1	3/4-14	-	32	2.36	60	3.72	94.5	2.20	56
12G-16FBSPORX90	7100-9681	3/4	19.1	1-11	-	41	2.76	70	4.42	112.2	2.41	61.2
16G-16FBSPORX90	7100-9163	1	25.4	1-11	-	41	2.76	70	5.16	131.09	2.93	74.3
20G-20FBSPORX90	7100-9164	1 1/4	31.8	1 1/4-11	-	50	3.15	80	5.96	151.37	3.64	92.4

MegaCrimp™ 编织管一体式接头

英制铰接式直接头

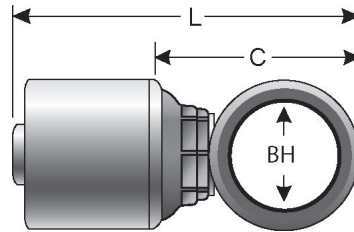

产品描述	编号	⊖		L		C		BH
		"	mm	"	mm	"	mm	mm
4G-4BSPBJ	7100-92565	1/4	6.4	2.10	53.4	1.19	30.3	13.2
6G-6BSPBJ	7100-92575	3/8	9.5	2.20	55.8	1.30	32.4	16.8
8G-8BSPBJ	7100-92925	1/2	12.7	2.80	70.7	1.50	38.2	21.0

公制铰接式

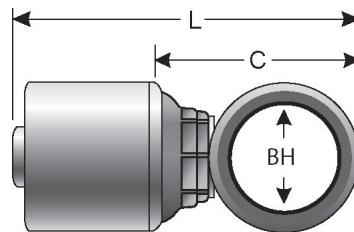

产品描述	编号	⊖		L		C		BH
		"	mm	"	mm	"	mm	mm
4G-12DBJ	7100-91195	1/4	6.4	2.03	51.4	1.11	28.3	12.1
6G-12DBJ	7100-98125	3/8	9.5	2.20	56.0	1.11	28.1	12.1
6G-14DBJ	7100-91275	3/8	9.5	2.30	58.3	1.20	30.4	14.1
6G-16DBJ	7100-91285	3/8	9.5	2.20	55.8	1.27	32.4	16.1
6G-18DBJ	7100-91295	3/8	9.5	2.28	57.8	1.35	34.4	18.1
8G-18DBJ	7100-91305	1/2	12.7	2.64	67.2	1.37	34.7	18.1
12G-26DBJ	7100-93895	3/4	19.1	3.73	94.7	1.72	43.7	26.1
16G-30DBJ	7100-94995	1	25.4	4.30	109.2	2.06	52.4	30.1